

P-4150
12227
21054

1. GENERAL WALL THICKNESS:- 1.05 mm., UNLESS OTHERWISE SPECIFIED
2. F = FULL RADIUS (8)
3. WEIGHT OF 16' (4878 mm.) LONG PIECE:- 3.800 kgs (AVERAGE)

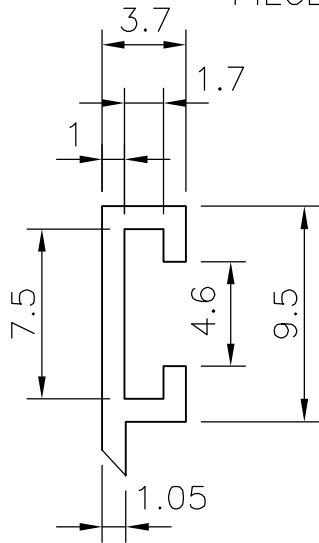

DETAIL 'A'
(3:1)

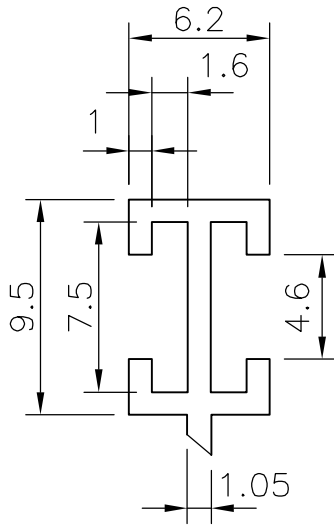

DETAIL 'B'
(3:1)

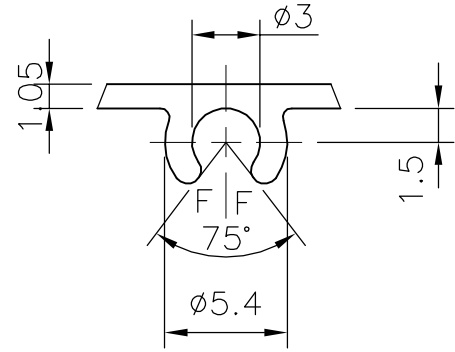

DETAIL 'C'
(3:1)

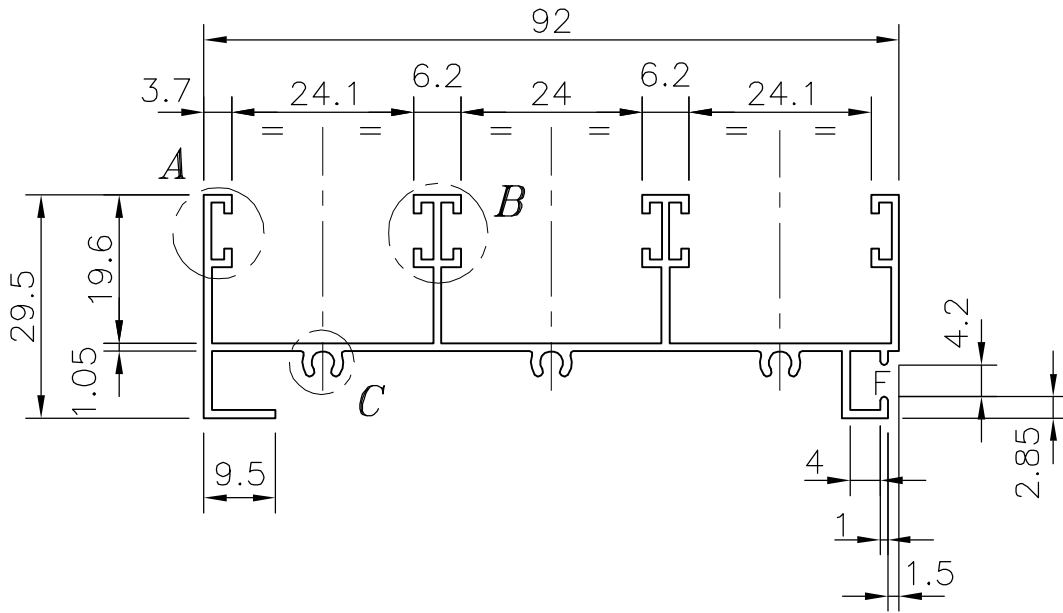

JINDAL ALUMINIUM LTD.
BANGALORE-560073 (INDIA)

	NAME	DATE
DRAWN	R.D.Sharma	21-02-03
CHECKED		
APPROVED		

1. ALL DIMENSIONS ARE IN mm.
2. ROUND OFF ALL SHARP CORNERS WITH 0.40 mm.
3. TOLERANCES WILL BE AS PER IS: 3965-1981 UNLESS OTHERWISE SPECIFIED

PARTY'S NAME	GENERAL CATEGORY, KOLKATA MARKET
PARTY'S DRAWING No.	LIGHTER OF SECTION NO. 8776
ALLOY & TEMPER	HE9 WP
DESCRIPTION	3-TRACK TOP

SCALE	1:1 & 3:1
AREA mm ²	287.9
PERIMETER mm.	543.5
WEIGHT kg/m	0.777
SECTION No.	21054
DRAWING No.	21054