

P-4151
12228
21055

1. GENERAL WALL THICKNESS:- 1.0 mm.
2. F = FULL RADIUS (8)
3. WEIGHT OF 16' (4878 mm.) LONG PIECE:- 4.220 kgs (AVERAGE)

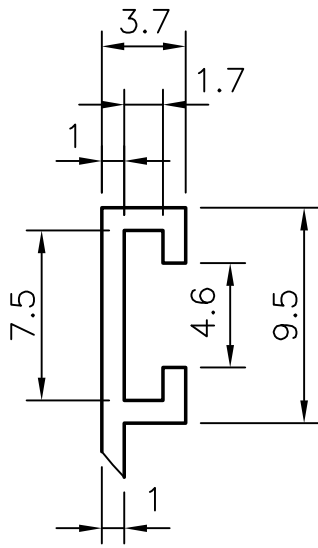

DETAIL 'A'
(3:1)

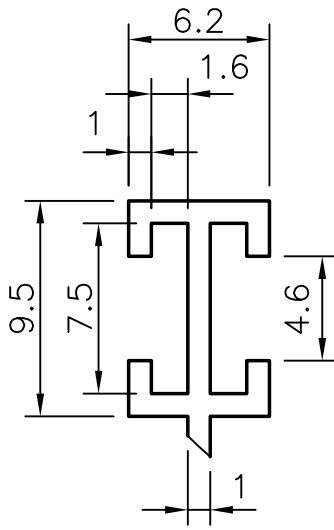

DETAIL 'B'
(3:1)

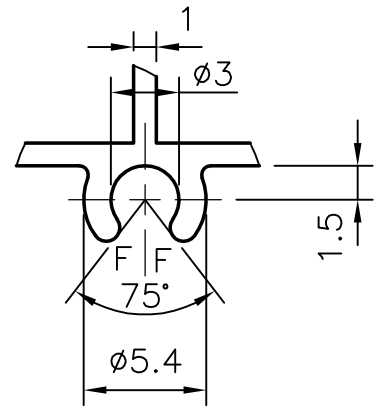

DETAIL 'C'
(3:1)

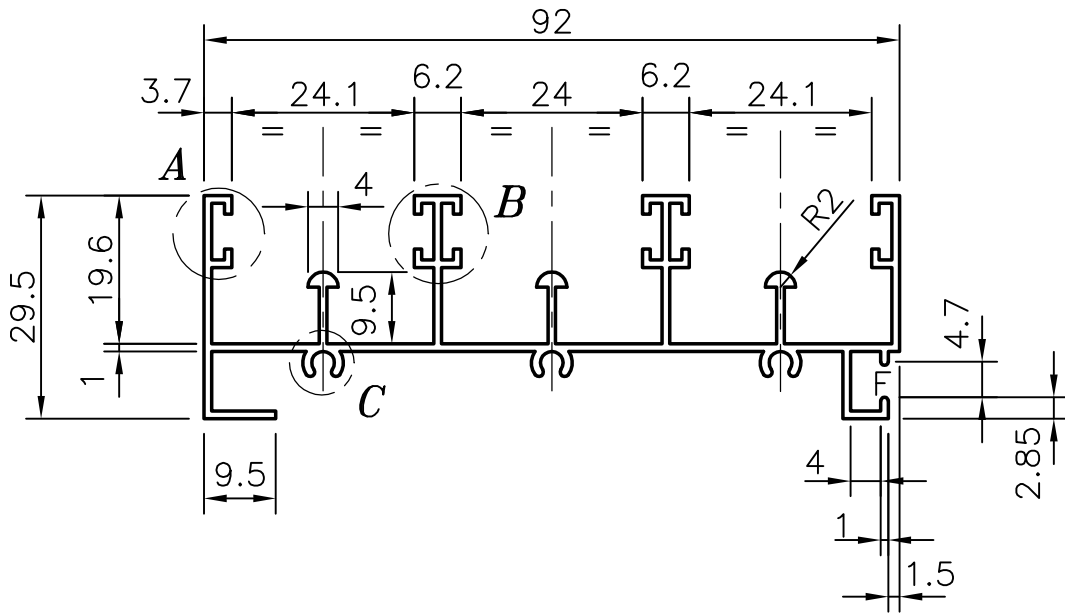

SYMBOL OF QUALITY
AN ISO 9002 COMPANY

JINDAL ALUMINIUM LTD.
BANGALORE-560073 (INDIA)

	NAME	DATE
DRAWN	R.D.Sharma	21-02-03
CHECKED		
APPROVED		

1. ALL DIMENSIONS ARE IN mm.
2. ROUND OFF ALL SHARP CORNERS WITH 0.40 mm.
3. TOLERANCES WILL BE AS PER IS: 3965-1981 UNLESS OTHERWISE SPECIFIED

SCALE	1:1 & 3:1
-------	-----------

PARTY'S NAME	GENERAL CATEGORY, KOLKATA MARKET
PARTY'S DRAWING No.	LIGHTER OF SECTION NO. 8784
ALLOY & TEMPER	HE9 WP
DESCRIPTION	3-TRACK BOTTOM

AREA mm ²	320.8
PERIMETER mm.	617
WEIGHT kg/m	0.866
SECTION No.	21055
DRAWING No.	21055