

12276

21056

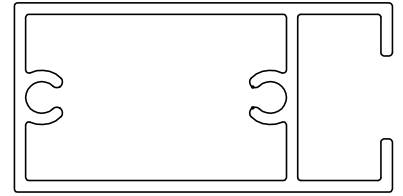

SCALE 1:1

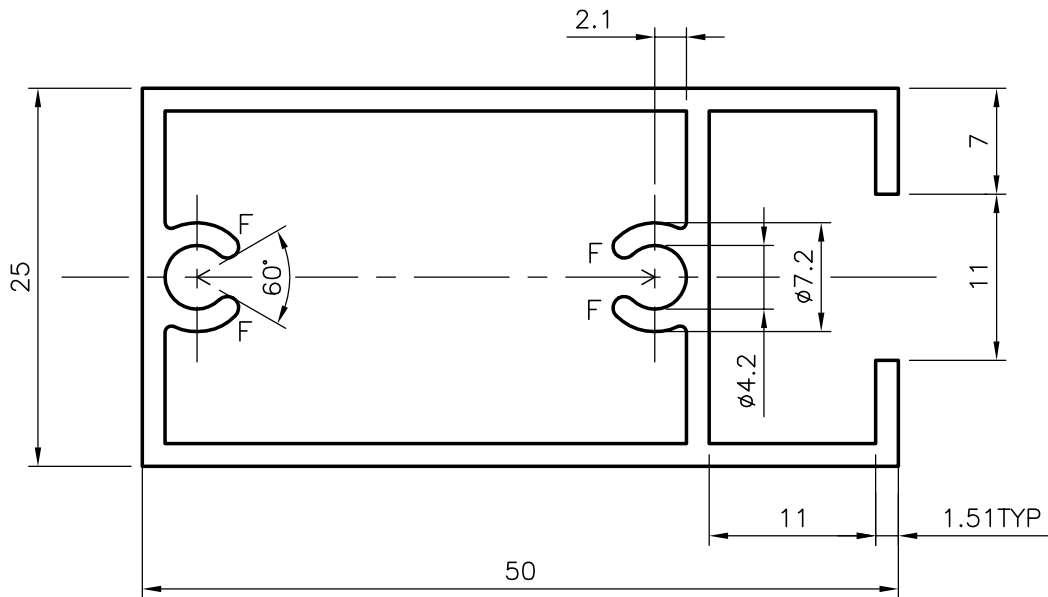

GENERAL WALL THICKNESS = 1.51mm

F = FULL RADII (4 PLACE)

NO OF PICES REQUIRED IN 100kgs :- 38 (AVERAGE)



SYMBOL OF QUALITY
AN ISO 9001 COMPANY

JINDAL ALUMINIUM LTD.
BANGALORE-560073 (INDIA)

	NAME	DATE
DRAWN	D K SHAW	04-11-2003
CHECKED		
APPROVED		

1. ALL DIMENSIONS ARE IN mm.
2. ROUND OFF ALL SHARP CORNERS WITH 1.00 mm.
3. TOLERANCES WILL BE AS PER IS:2673-2002 UNLESS OTHERWISE SPECIFIED

SCALE	2:1
AREA mm ²	265.80
PERIMETER mm.	194.90
WEIGHT kg/m	0.717

PARTY'S NAME

-

DRAWING No.

SECTION No.

PARTY'S DRAWING No.

HEAVIER OF SECTION NO. (8788) 12255

12276

12276

ALLOY & TEMPER

HE9 WP

21056

21056

DESCRIPTION

WINDOW SECTION