

P-4878

83106

21064

DETAIL "A"  
SCALE 5:1

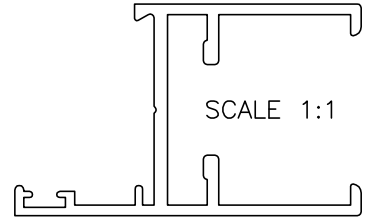

SCALE 1:1

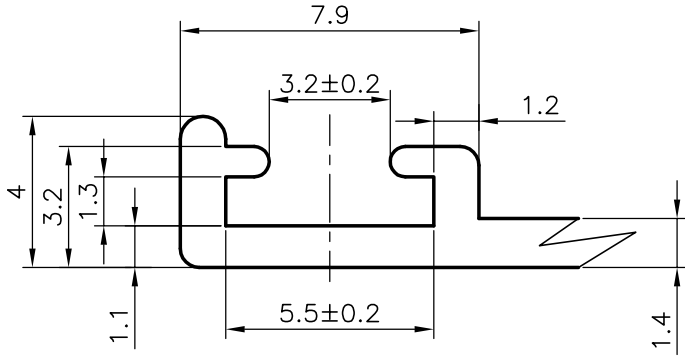

F = FULL RADIUS (4 PLACES)  
R = 0.50mm RADIUS (12 PLACES)  
V = VEE GROOVE 0.3x90° ( 1 PLACE)

DETAIL "A"

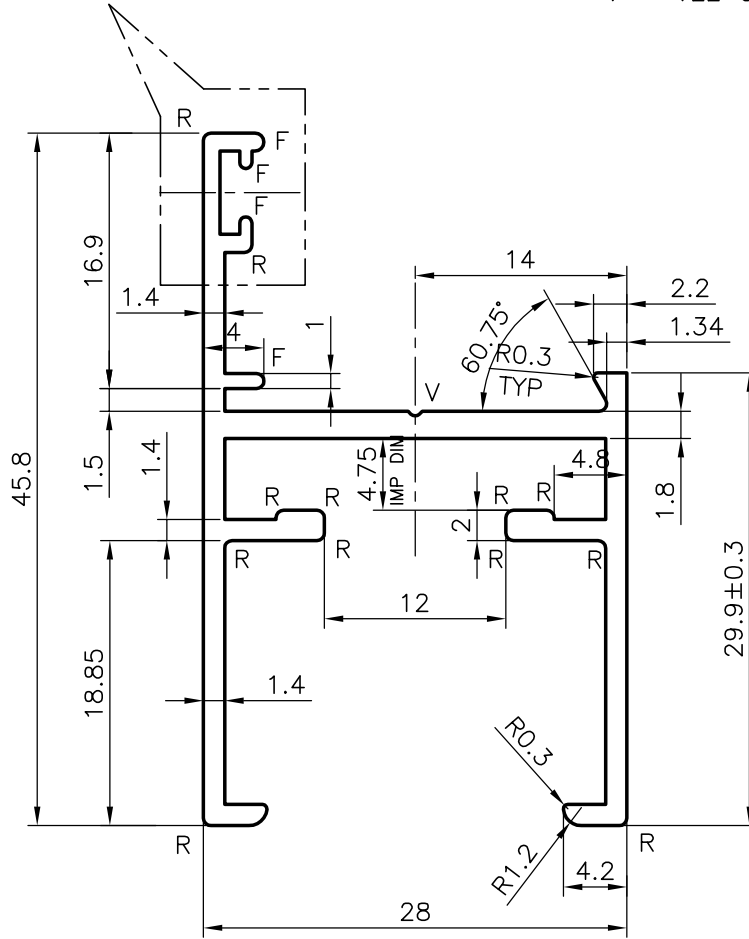

SYMBOL OF QUALITY  
AN ISO 9002 COMPANY

**JINDAL ALUMINIUM LTD.**  
BANGALORE-560073 (INDIA)

	NAME	DATE
DRAWN	RAGHAVENDRA	27-05-2004
CHECKED		
APPROVED		

1. ALL DIMENSIONS ARE IN mm.
2. ROUND OFF ALL SHARP CORNERS WITH 0.40 mm.
3. TOLERANCES WILL BE AS PER BS:1474-1987 UNLESS OTHERWISE SPECIFIED

SCALE	2:1
AREA mm <sup>2</sup>	188.851
PERIMETER mm.	258.567
WEIGHT kg/m	0.510

PARTY'S NAME	STAR GLASS ALUMINIUM C.C, SOUTH AFRICA
PARTY'S DRAWING No.	AF-2101
ALLOY & TEMPER	6063 T6
DESCRIPTION	EQUAL LEG

DRAWING No.	SECTION No.
P-4878	-
83106	83106
21064	21064