

P-4879
83107
21065

DETAIL "A"
SCALE 5:1

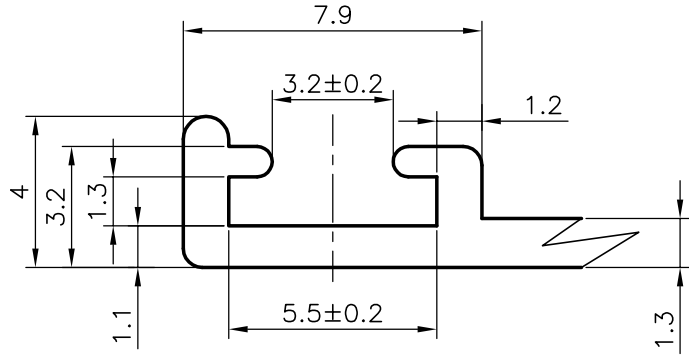

DETAIL "A"

- F = FULL RADIUS (8 PLACES)
- R = 0.50mm RADIUS (12 PLACES)
- V = VEE GROOVE 0.3x90° (1 PLACE)

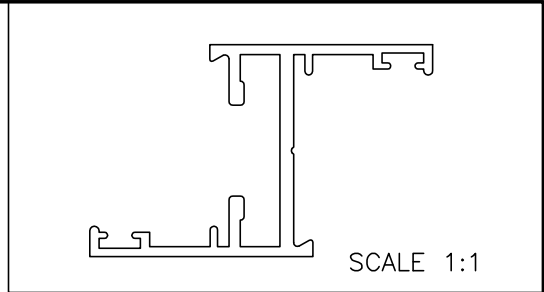

MATCHING SECTION
SCALE 1:1

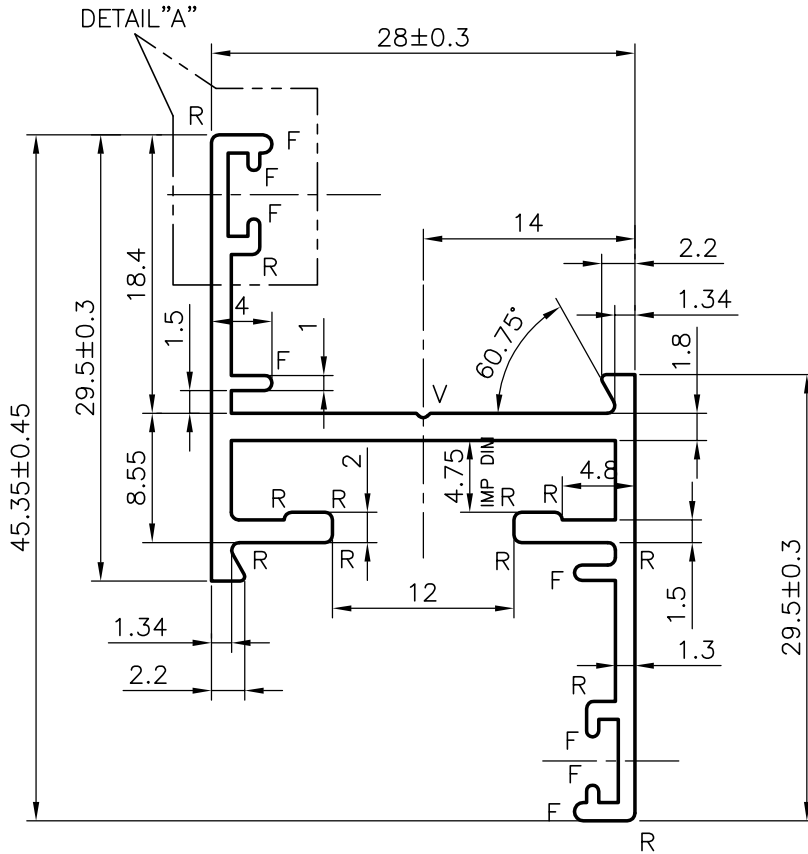
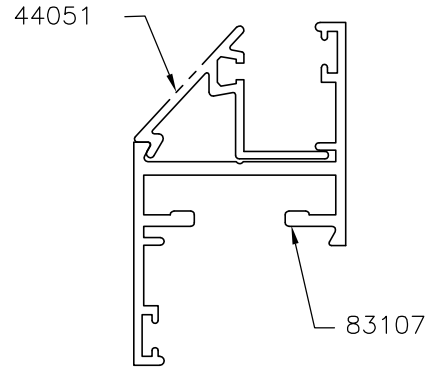

SYMBOL OF QUALITY
AN ISO 9002 COMPANY

JINDAL ALUMINIUM LTD.
BANGALORE-560073 (INDIA)

	NAME	DATE
DRAWN	RAGHAVENDRA	27-05-2004
CHECKED		
APPROVED		

1. ALL DIMENSIONS ARE IN mm.
2. ROUND OFF ALL SHARP CORNERS WITH 0.40 mm.
3. TOLERANCES WILL BE AS PER BS:1474-1987 UNLESS OTHERWISE SPECIFIED

SCALE	2:1
AREA mm ²	164.525
PERIMETER mm.	234.034
WEIGHT kg/m	0.444

PARTY'S NAME	STAR GLASS ALUMINIUM C.C, SOUTH AFRICA
PARTY'S DRAWING No.	AF-2103
ALLOY & TEMPER	6063 T6
DESCRIPTION	UNEQUAL LEG

DRAWING No.	SECTION No.
P-4879	-
83107	83107
21065	21065