

P-3890

S897

21070

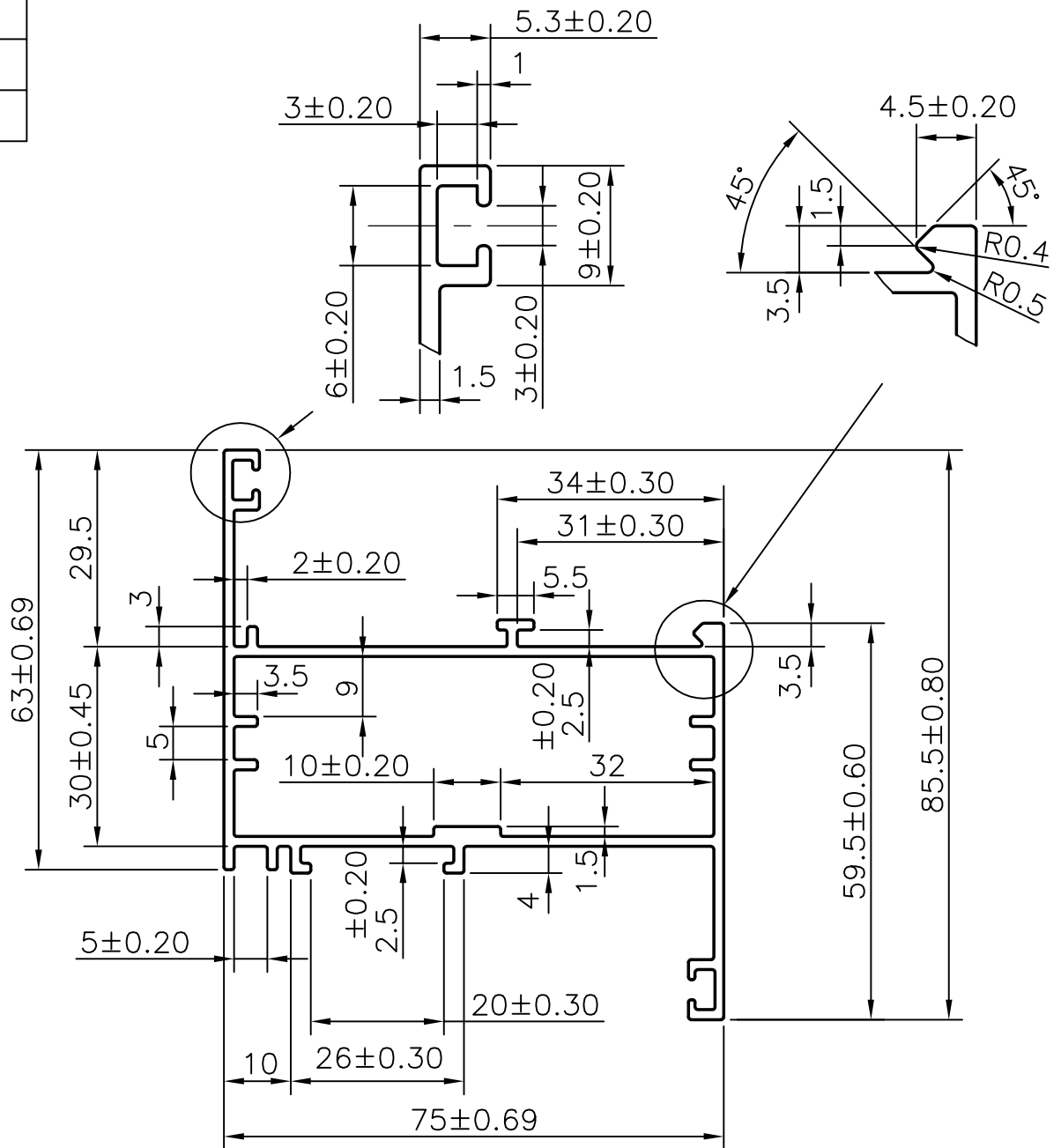

- 1 GENERAL WALL THICKNESS:- 1.50 mm.±0.20
- 2 MATCHING SECTION:- S899



SYMBOL OF QUALITY
AN ISO 9002 COMPANY

JINDAL ALUMINIUM LTD.
BANGALORE-560073 (INDIA)

	NAME	DATE
DRAWN	R.D.Sharma	01-07-02
CHECKED		
APPROVED		

- 1. ALL DIMENSIONS ARE IN mm.
- 2. ROUND OFF ALL SHARP CORNERS WITH 0.40 mm.
- 3. TOLERANCES WILL BE AS PER IS 6477-1983 UNLESS OTHERWISE SPECIFIED

SCALE	3:1
AREA mm ²	508.5
PERIMETER	420 mm
WEIGHT kg/m	1.373
SECTION No.	21070
DRAWING No.	21070

PARTY'S NAME	ALUMINIUM GLASS & GLAZING, CHENNAI
PARTY'S DRAWING No.	AS PER DRAWING
ALLOY & TEMPER	HE9 WP
DESCRIPTION	WINDOW SECTION