

P-4686

21074

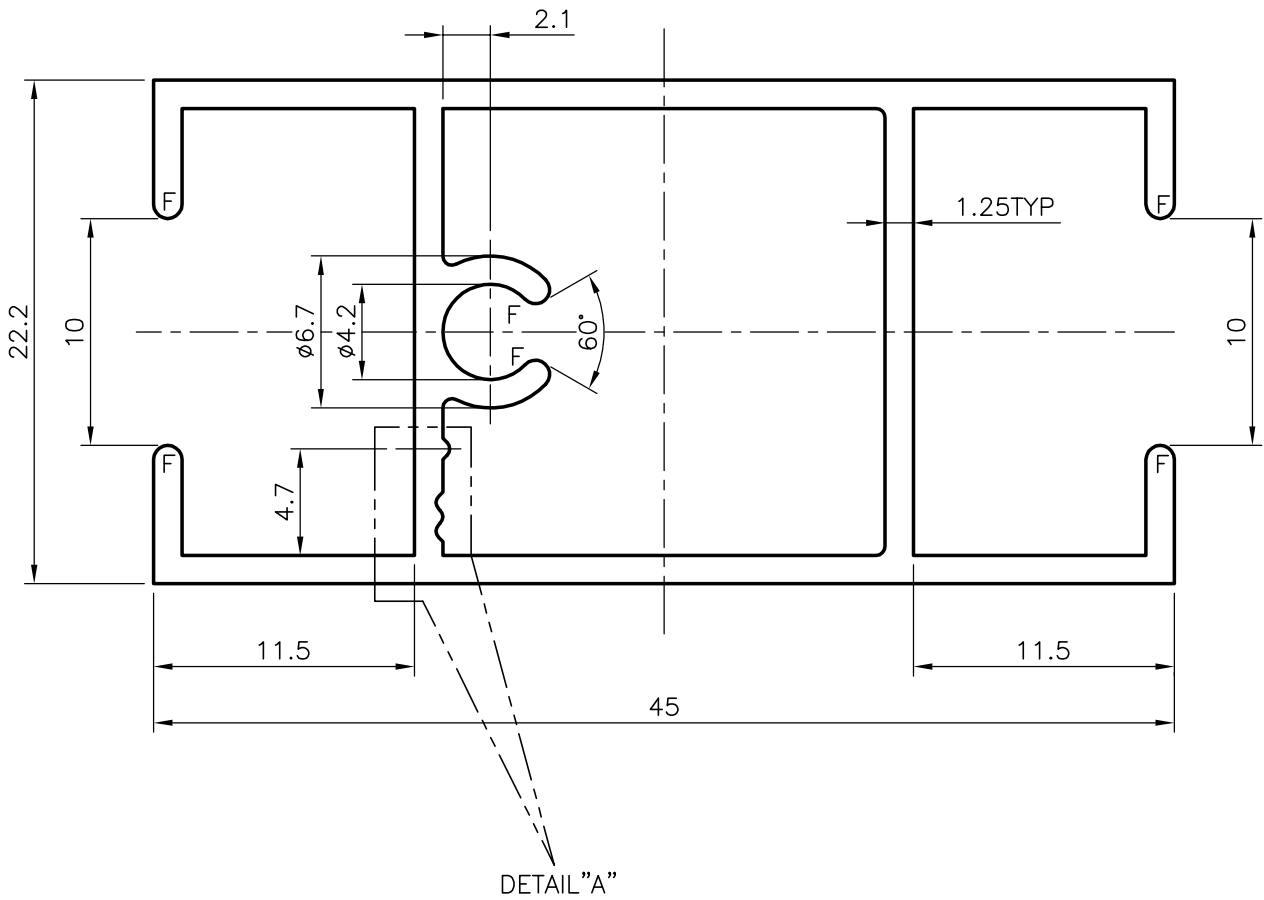

GENERAL WALL THICKNESS = 1.25mm
F = FULL RADIUS (6 PLACES)

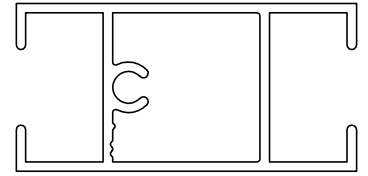
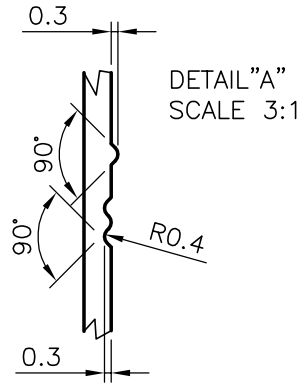

SYMBOL OF QUALITY
AN ISO 9002 COMPANY

JINDAL ALUMINIUM LTD.
BANGALORE-560073 (INDIA)

	NAME	DATE
DRAWN	RAGHAVENDRA	16-11-2004
CHECKED		
APPROVED		

1. ALL DIMENSIONS ARE IN mm.
2. ROUND OFF ALL SHARP CORNERS WITH 0.40 mm.
3. TOLERANCES WILL BE AS PER BS:1474-1987 UNLESS OTHERWISE SPECIFIED

SCALE	3:1
AREA mm ²	198.376
PERIMETER mm.	217.054
WEIGHT kg/m	0.536

PARTY'S NAME	SYDNEY ALUMINIUM & GLASS - DOHA
PARTY'S DRAWING No.	AS PER SAMPLE
ALLOY & TEMPER	6063 T6
DESCRIPTION	WINDOW SECTION

DRAWING No.	SECTION No.
P-4686	-
21074	21074