

P-4687

21075

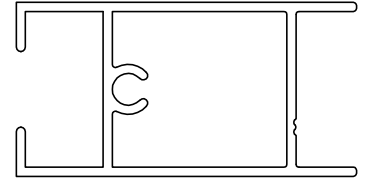

SCALE 1:1

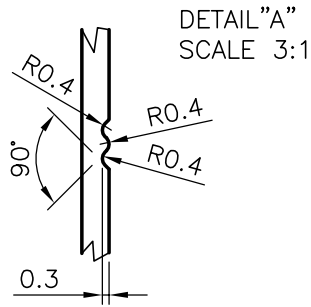
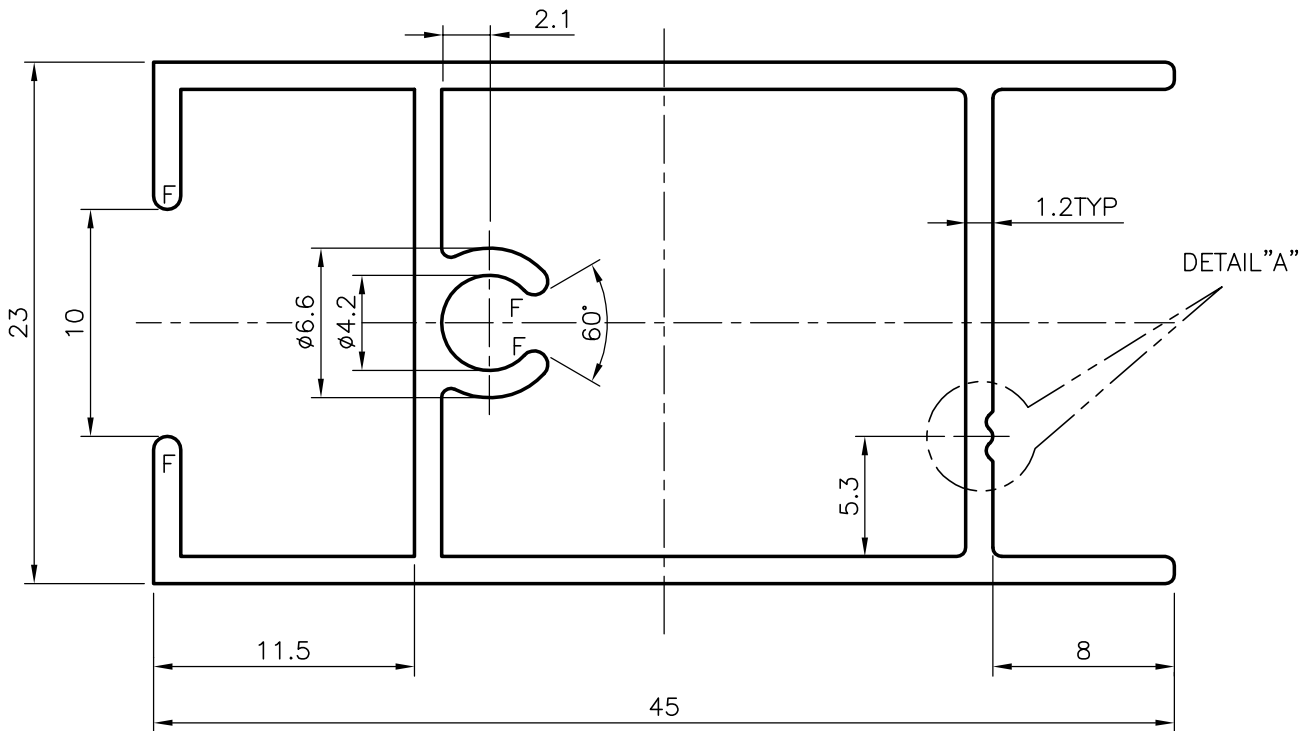

GENERAL WALL THICKNESS = 1.20mm

F = FULL RADIUS (4 PLACES)



SYMBOL OF QUALITY
AN ISO 9002 COMPANY

JINDAL ALUMINIUM LTD.
BANGALORE-560073 (INDIA)

| | NAME | DATE |
|----------|-------------|------------|
| DRAWN | RAGHAVENDRA | 16-11-2004 |
| CHECKED | | |
| APPROVED | | |

1. ALL DIMENSIONS ARE IN mm.
2. ROUND OFF ALL SHARP CORNERS WITH 0.40 mm.
3. TOLERANCES WILL BE AS PER BS:1474-1987 UNLESS OTHERWISE SPECIFIED

| | |
|----------------------|---------|
| SCALE | 3:1 |
| AREA mm ² | 182.103 |
| PERIMETER mm. | 194.534 |
| WEIGHT kg/m | 0.492 |

| | |
|---------------------|------------------------------------|
| PARTY'S NAME | SYDNEY ALUMINIUM & GLASS - DOHA |
| PARTY'S DRAWING No. | AS PER SAMPLE & AS PER REQUIREMENT |
| ALLOY & TEMPER | 6063 T6 |
| DESCRIPTION | WINDOW SECTION |

| DRAWING No. | SECTION No. |
|-------------|-------------|
| P-4687 | - |
| 21075 | 21075 |
| | |
| | |