

P-4702

21079

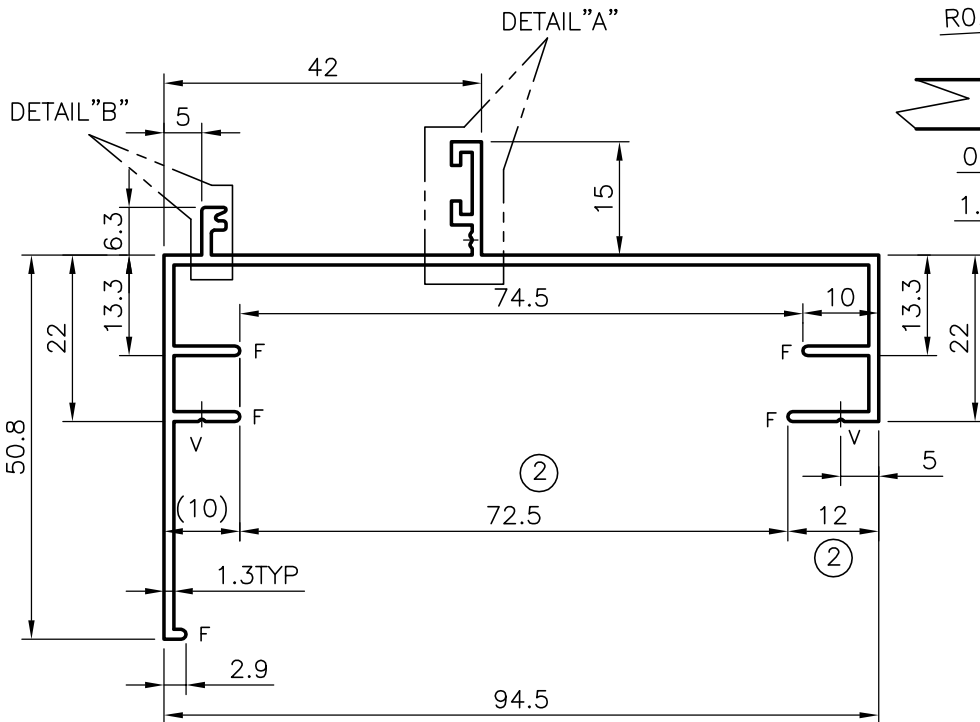
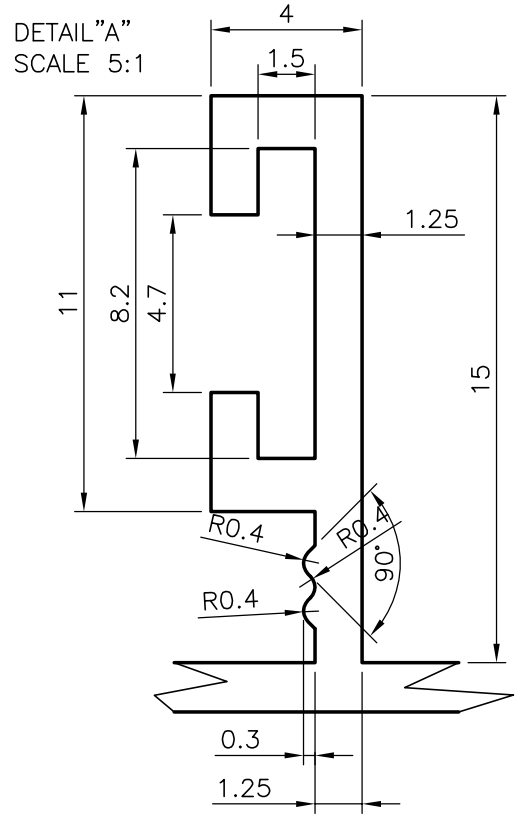
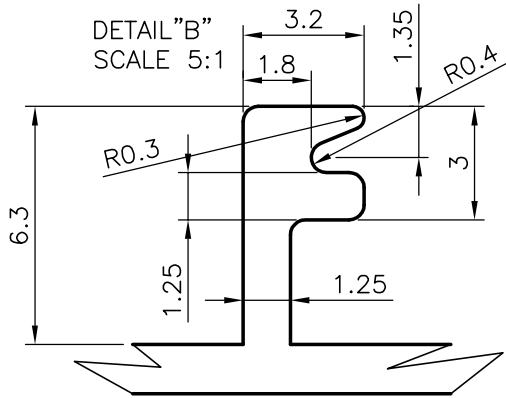

ISSUE-2 DIMENSIONS CHANGED FROM  
10.00 TO 12.00mm  
74.50 TO 72.50mm

GENERAL WALL THICKNESS = 1.30mm  
F = FULL RADIUS (5 PLACES)  
V = VEE GROOVE 0.3x90° (2 PLACES)



SYMBOL OF QUALITY  
AN ISO 9001 COMPANY

**JINDAL ALUMINIUM LTD.**  
BANGALORE-560073 (INDIA)

	NAME	DATE
DRAWN	RAGHAVENDRA	06-01-2005
CHECKED		
APPROVED		

1. ALL DIMENSIONS ARE IN mm.
2. ROUND OFF ALL SHARP CORNERS WITH 0.40 mm.
3. TOLERANCES WILL BE AS PER BS:1474-1987 UNLESS OTHERWISE SPECIFIED

SCALE	1:1
AREA mm <sup>2</sup>	306.29
PERIMETER mm.	472.568
WEIGHT kg/m	0.827

PARTY'S NAME	SYDNEY ALUMINIUM & GLASS - DOHA
PARTY'S DRAWING No.	AS PER SAMPLE
ALLOY & TEMPER	6063 T6
DESCRIPTION	WINDOW SECTION

DRAWING No.	SECTION No.
P-4702	-
21079	21079-ISSUE-2