

P-4068

S949

21086

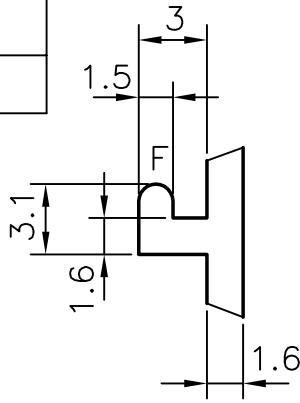

DETAIL 'C'
(3:1)

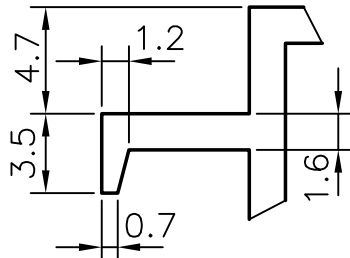

DETAIL 'B'
(3:1)

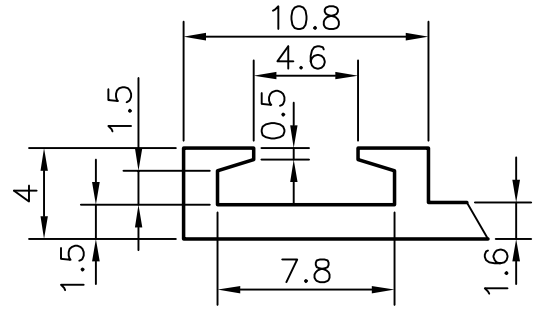

DETAIL 'A'
(3:1)

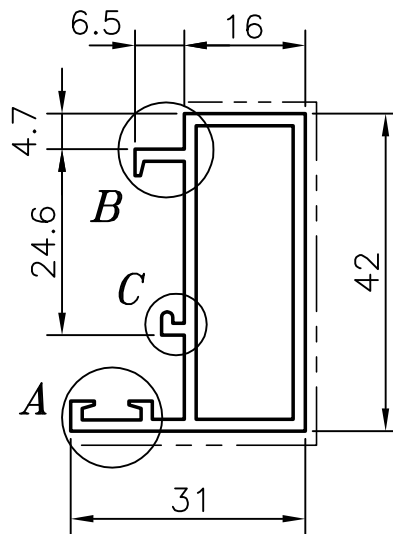

1. GENERAL WALL THICKNESS:- 1.60 mm.
2. F = FULL RADIUS
3. ---- EXPOSED SURFACE



SYMBOL OF QUALITY
AN ISO 9002 COMPANY

JINDAL ALUMINIUM LTD.
BANGALORE-560073 (INDIA)

	NAME	DATE
DRAWN	R.D.Sharma	31-12-02
CHECKED		
APPROVED		

1. ALL DIMENSIONS ARE IN mm.
2. ROUND OFF ALL SHARP CORNERS WITH 0.40 mm.
3. TOLERANCES WILL BE AS PER IS: 6477-1983 UNLESS OTHERWISE SPECIFIED

SCALE	1:1 & 3:1
AREA mm ²	227.2
PERIMETER mm.	186

PARTY'S NAME AJIT INDIA (MADRAS) PVT. LTD., CHENNAI

PARTY'S DRAWING No. AS PER SKETCH

WEIGHT kg/m 0.613

ALLOY & TEMPER HE9 WP

SECTION No. 21086

DESCRIPTION WINDOW SECTION

DRAWING No. 21086