

P-5529

21101

1. GENERAL WALL THICKNESS:- 2.0 mm.

2. F = FULL RADIUS (8 PLACES)

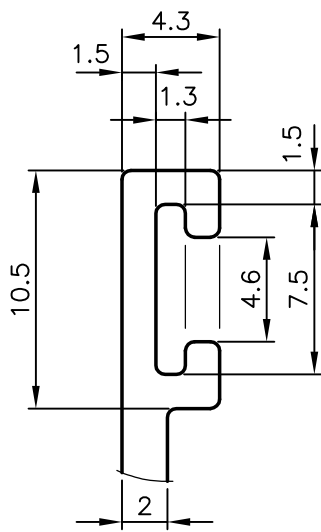

DETAIL-A

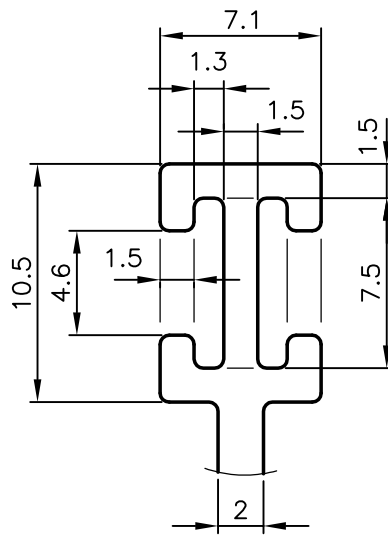

DETAIL-B

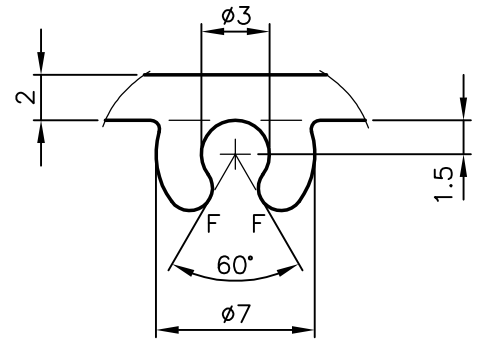

DETAIL-C

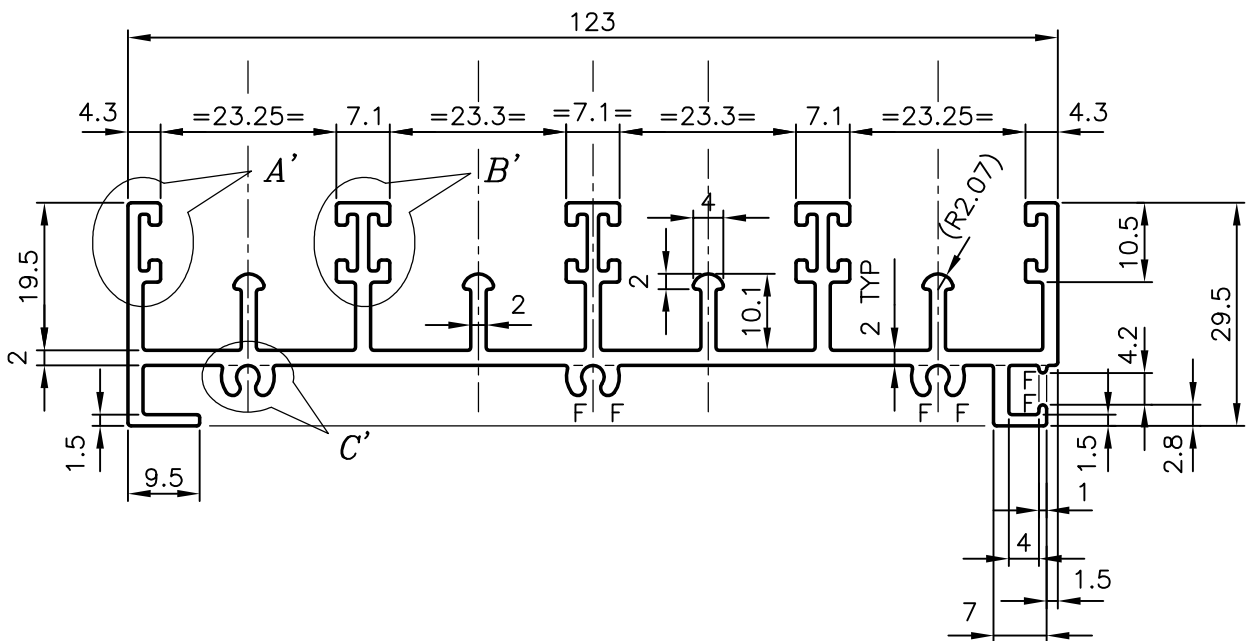

SYMBOL OF QUALITY
AN ISO 9001 COMPANY

JINDAL ALUMINIUM LTD.
BANGALORE-560073 (INDIA)

1. ALL DIMENSIONS ARE IN mm.
2. ROUND OFF ALL SHARP CORNERS WITH 0.40 mm.
3. TOLERANCES WILL BE AS PER IS:3965-1981 UNLESS OTHERWISE SPECIFIED

	NAME	DATE
DRAWN	MALINGAPPA	27-05-2005
CHECKED		
APPROVED		
SCALE	1:1 & 3:1	
AREA mm ²	709.076	
PERIMETER mm.	743.644	
WEIGHT kg/m	1.915	
DRAWING No.	SECTION No.	
P-5529	-	
21101	21101	

PARTY'S NAME	GENERAL CATEGORY, KOLKATA MARKET
PARTY'S DRAWING No.	HEAVIER OF SECTION NO. 20910
ALLOY & TEMPER	HE9 WP
DESCRIPTION	4-TRACK BOTTOM