

P-5434-3

21106

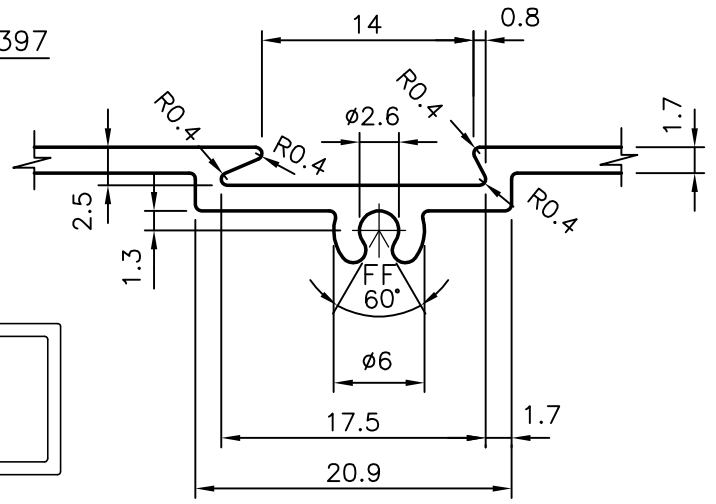

DETAIL-A

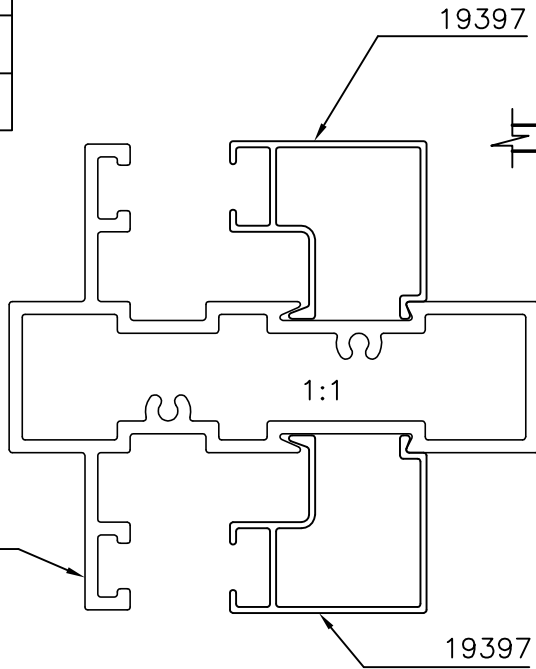
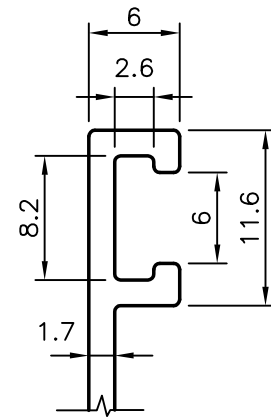
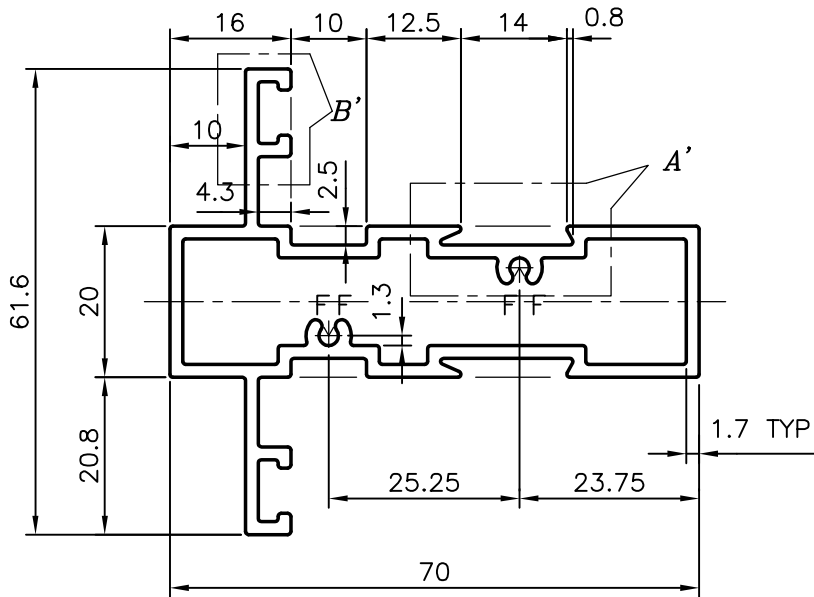

DETAIL-B

F = FULL RADIUS (4 PLACES)  
 GENERAL WALL THICKNESS = 1.7 mm



SYMBOL OF QUALITY  
 AN ISO 9002 COMPANY

**JINDAL ALUMINIUM LTD.**  
 BANGALORE-560073 (INDIA)

	NAME	DATE
DRAWN	MALINGAPPA	16-06-2005
CHECKED		
APPROVED		
SCALE	1:1, 2:1	
AREA mm <sup>2</sup>	468.61	
PERIMETER mm.	328.841	
WEIGHT kg/m	1.265	
DRAWING No.	SECTION No.	
P-5434-3	-	
21106	21106	

- ALL DIMENSIONS ARE IN mm.
- ROUND OFF ALL SHARP CORNERS WITH 0.40 mm.
- TOLERANCES WILL BE AS PER IS:6477-1983 UNLESS OTHERWISE SPECIFIED

PARTY'S NAME	GENERAL CATEGORY, DELHI MARKET
PARTY'S DRAWING No.	AS PER SAMPLE/WEIGHT
ALLOY & TEMPER	HE9 WP
DESCRIPTION	WINDOW SECTION