

P-5775-2

21119

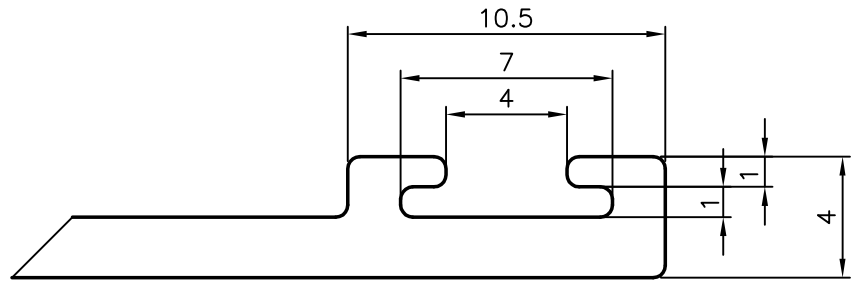

DETAIL A

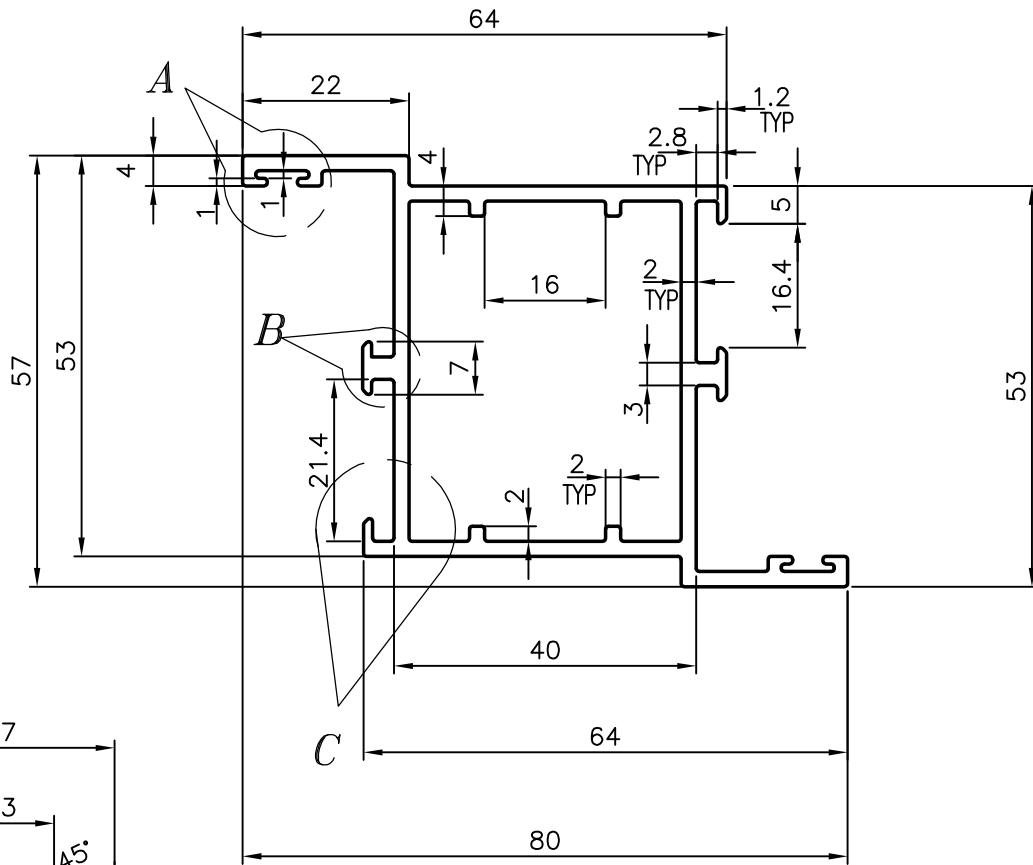

GENERAL WALL THICKNESS 2.0mm(TYP)

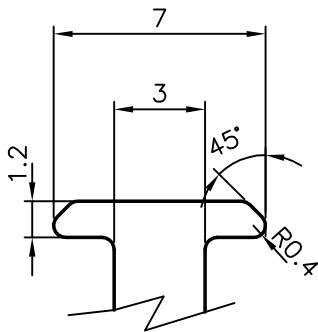

DETAIL B

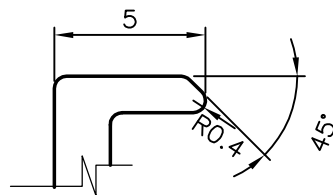

DETAIL C



SYMBOL OF QUALITY  
AN ISO 9001 COMPANY

**JINDAL ALUMINIUM LTD.**  
BANGALORE-560073 (INDIA)

	NAME	DATE
DRAWN	J.P.KAUSHIK	23-12-2005
CHECKED		
APPROVED		
SCALE		1:1
AREA mm <sup>2</sup>		528.121
PERIMETER mm.		351.417
WEIGHT kg/m		1.426
DRAWING No.	SECTION No.	
P-5775-2	-	
21119	21119	

1. ALL DIMENSIONS ARE IN mm.
2. ROUND OFF ALL SHARP CORNERS WITH 0.40 mm.
3. TOLERANCES WILL BE AS PER IS:6477-1983 UNLESS OTHERWISE SPECIFIED

PARTY'S NAME	GENERAL CATEGORY, LUCKNOW MARKET
PARTY'S DRAWING No.	AS PER SPECIFICATION
ALLOY & TEMPER	HE9 WP
DESCRIPTION	CASMENT WINDOW SECTION