

P-6306

21133

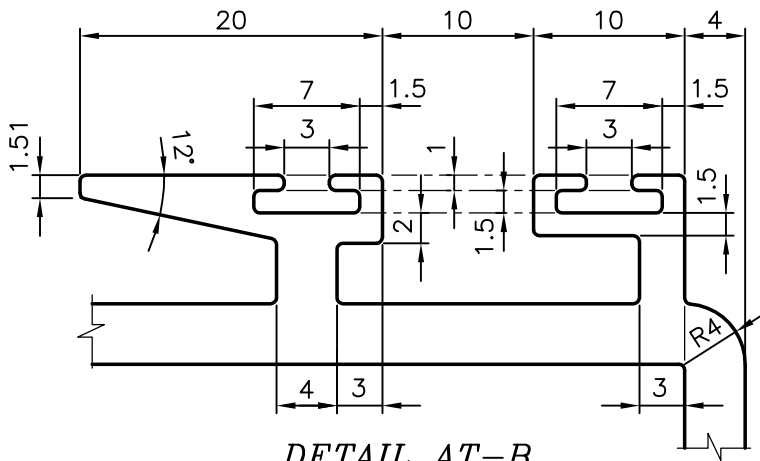

**DETAIL AT-B**

SCALE:- 2:1

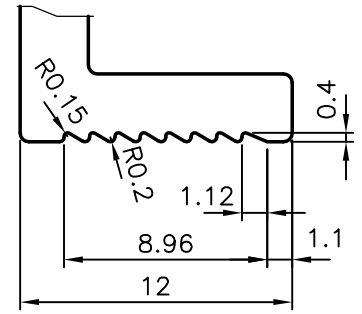

**DETAIL AT-A**

SCALE:- 3:1

UNSPECIFIED WALL THICKNESS = 3 mm

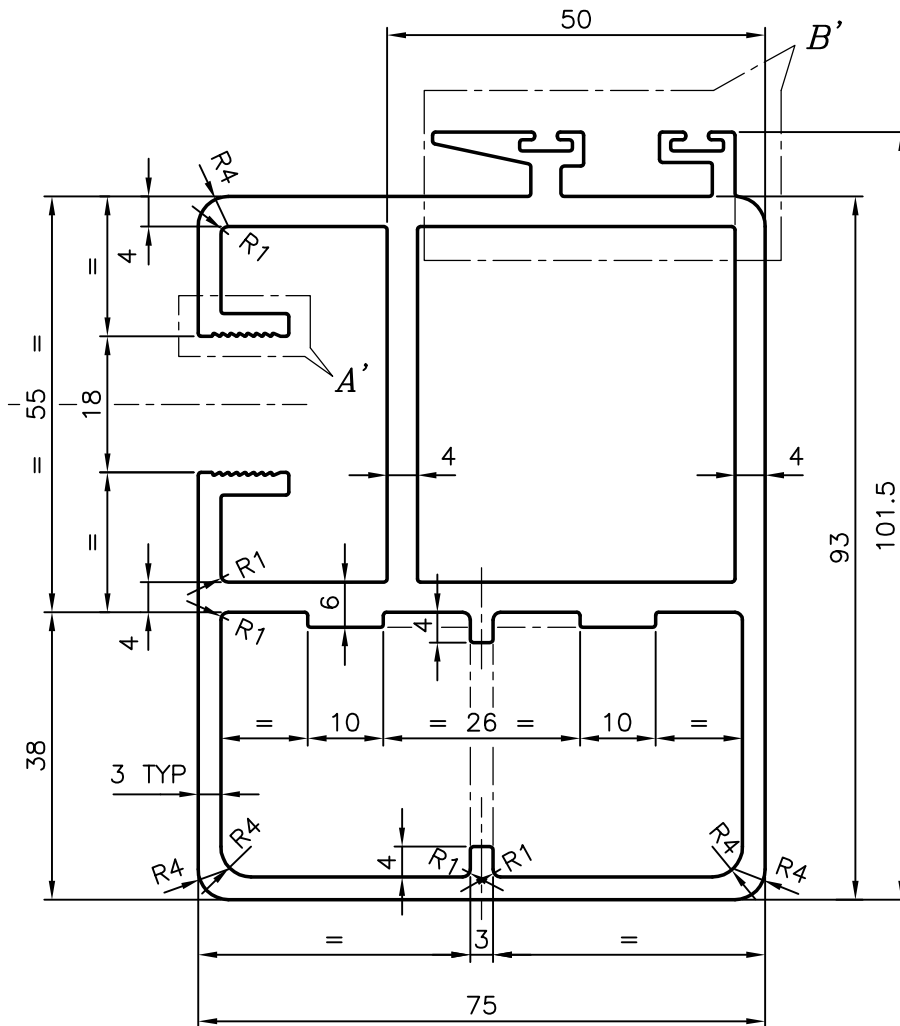

SYMBOL OF QUALITY  
AN ISO 9001 COMPANY

**JINDAL ALUMINIUM LTD.**  
BANGALORE-560073 (INDIA)

	NAME	DATE
DRAWN	MALINGAPPA	05-04-2006
CHECKED		
APPROVED		
SCALE	1:1	
AREA mm <sup>2</sup>	1718.634	
PERIMETER mm.	574.719	
WEIGHT kg/m	4.640	
DRAWING No.	SECTION No.	
P-6306	-	
21133	21133	

1. ALL DIMENSIONS ARE IN mm.
2. ROUND OFF ALL SHARP CORNERS WITH 0.40 mm.
3. TOLERANCES WILL BE AS PER IS:6477-1983 UNLESS OTHERWISE SPECIFIED

PARTY'S NAME	GENERAL CATEGORY, MUMBAI MARKET
PARTY'S DRAWING No.	AX-2402-33B
ALLOY & TEMPER	6063 T5
DESCRIPTION	WINDOW SECTION-INTERMEDIATE EXTERIOR SHUTTER