

P-6411

21142

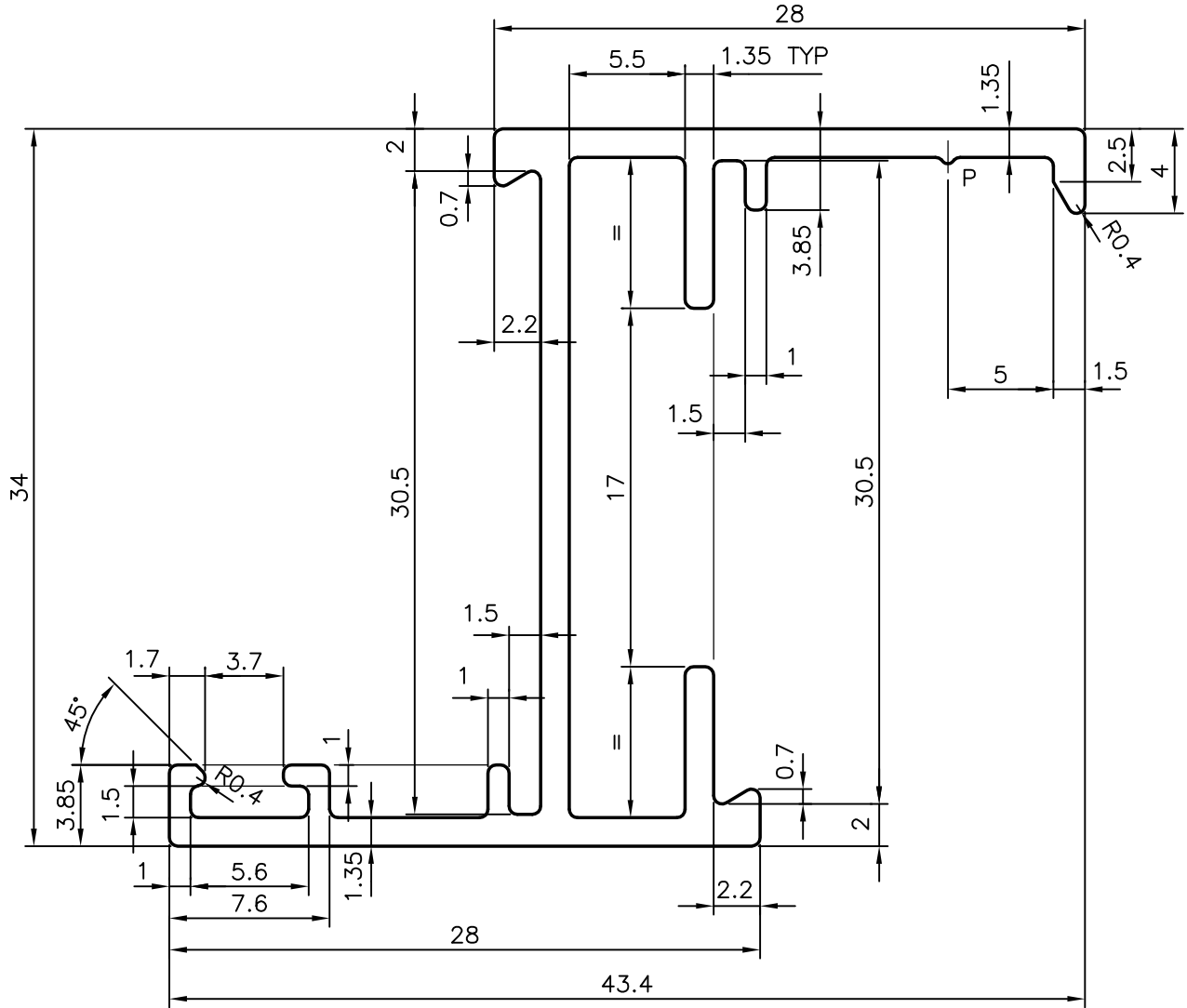

- 1. GENERAL WALL THICKNESS = 1.35 mm
- 2. P = PIP 0.3x90°xR0.3 (1 PLACE)

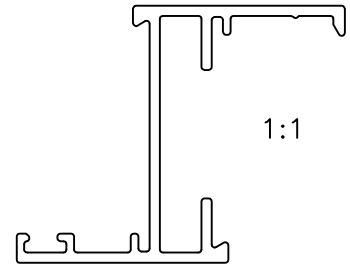
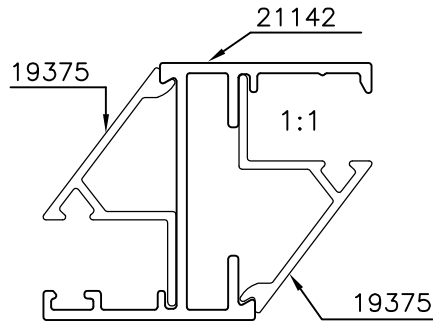

JINDAL ALUMINIUM LTD.
BANGALORE-560073 (INDIA)

	NAME	DATE
DRAWN	MALINGAPPA	18-05-2006
CHECKED		
APPROVED		
SCALE		3:1
AREA mm ²		157.223
PERIMETER mm.		228.883
WEIGHT kg/m		0.425
DRAWING No.	SECTION No.	
P-6411	-	
21142	21142	

1. ALL DIMENSIONS ARE IN mm. 2. ROUND OFF ALL SHARP CORNERS WITH 0.40 mm. 3. TOLERANCES WILL BE AS PER IS:3965-1981 UNLESS OTHERWISE SPECIFIED	
PARTY'S NAME	GENERAL CATEGORY, COCHIN MARKET
PARTY'S DRAWING No.	LIGHTER OF SECTION NO. 20914
ALLOY & TEMPER	HE9 WP
DESCRIPTION	WINDOW SECTION