

P-6492-1

21147

UNSPECIFIED WALL THICKNESS = 1.5 mm
 F = FULL RADIUS (4 PLACES)

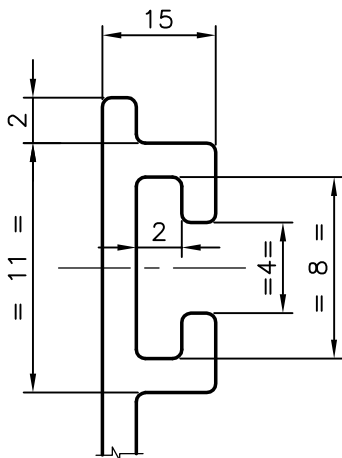
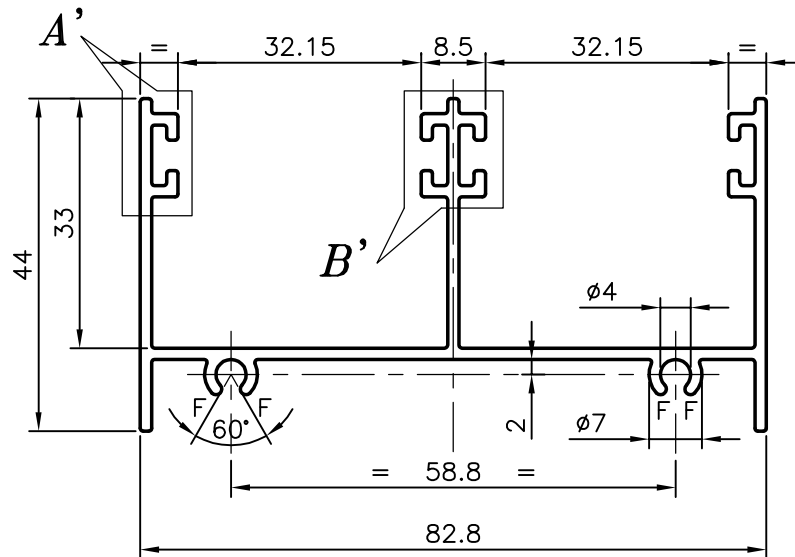

DETAIL-A
 SCALE:-3:1

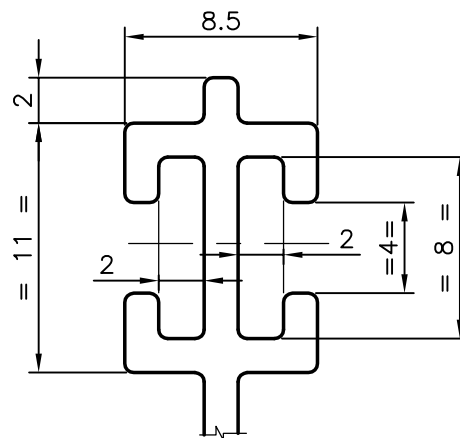

DETAIL-B
 SCALE:-3:1



SYMBOL OF QUALITY
 AN ISO 9001 COMPANY

JINDAL ALUMINIUM LTD.
 BANGALORE-560073 (INDIA)

	NAME	DATE
DRAWN	malingappa	27-06-2006
CHECKED		
APPROVED		
SCALE		1:1
AREA mm ²		397.543
PERIMETER mm.		515.446
WEIGHT kg/m		1.073
DRAWING No.	SECTION No.	
P-6492-1	-	
21147	21147	

1. ALL DIMENSIONS ARE IN mm.
2. ROUND OFF ALL SHARP CORNERS WITH 0.40 mm.
3. TOLERANCES WILL BE AS PER IS:3965-1981 UNLESS OTHERWISE SPECIFIED

PARTY'S NAME	GENERAL CATEGORY, COCHIN MARKET
PARTY'S DRAWING No.	LIGHTER OF SEC. NO. 20713
ALLOY & TEMPER	HE9 WP
DESCRIPTION	WINDOW SECTION