

P-6542

21148

UNSPECIFIED WALL THICKNESS = 1.5 mm

F = FULL RADIUS (6 PLACES)

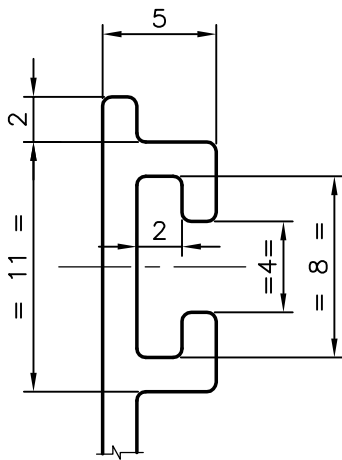
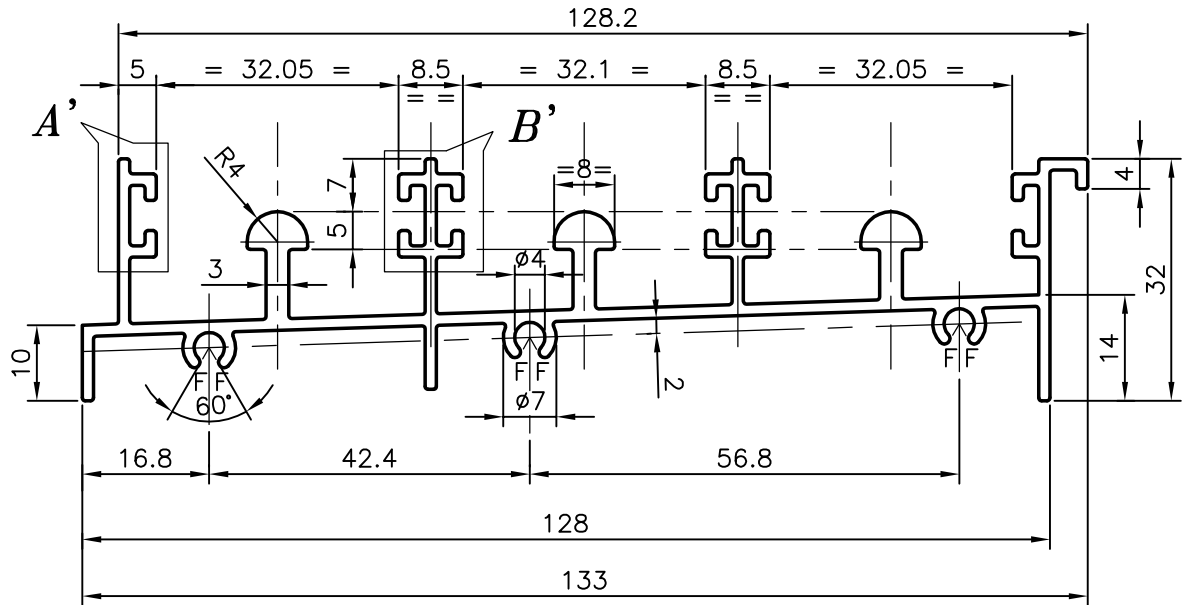

DETAIL-A
SCALE:-3:1

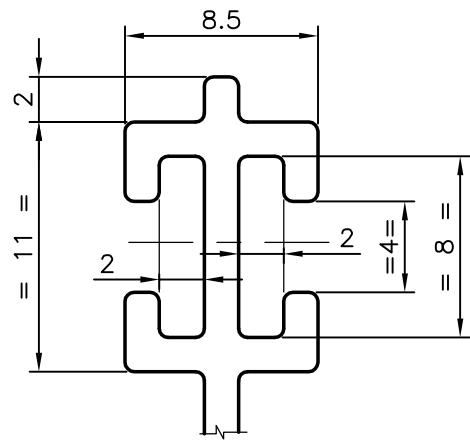

DETAIL-B
SCALE:-3:1



SYMBOL OF QUALITY
AN ISO 9001 COMPANY

JINDAL ALUMINIUM LTD.
BANGALORE-560073 (INDIA)

	NAME	DATE
DRAWN	malingappa	01-07-2006
CHECKED		
APPROVED		

1. ALL DIMENSIONS ARE IN mm.
2. ROUND OFF ALL SHARP CORNERS WITH 0.40 mm.
3. TOLERANCES WILL BE AS PER IS:3965-1981 UNLESS OTHERWISE SPECIFIED

SCALE	1:1
AREA mm ²	682.295
PERIMETER mm.	751.916
WEIGHT kg/m	1.842

PARTY'S NAME	GENERAL CATEGORY, COCHIN MARKET
PARTY'S DRAWING No.	LIGHTER OF SEC. NO. 20717
ALLOY & TEMPER	HE9 WP
DESCRIPTION	WINDOW SECTION

DRAWING No.	SECTION No.
P-6542	-
21148	21148