

P-6033

21150

1. GENERAL WALL THICKNESS:- 1.40 ± 0.20 mm.
2. F = FULL RADIUS (4)

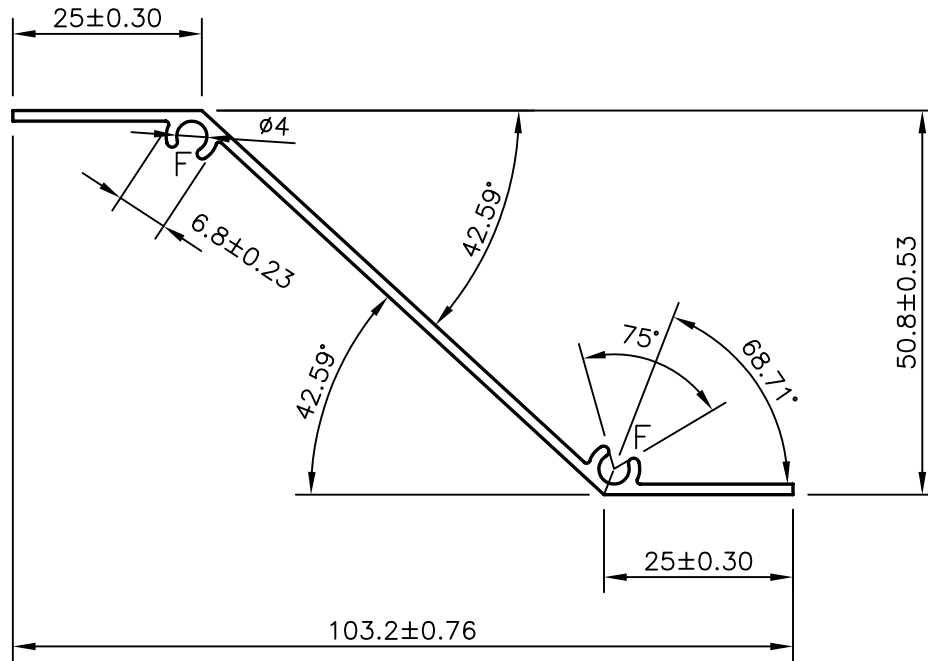

SYMBOL OF QUALITY
AN ISO 9002 COMPANY

JINDAL ALUMINIUM LTD.
BANGALORE-560073 (INDIA)

	NAME	DATE
DRAWN	MAHALINGAPPA	06-12-2005
CHECKED		
APPROVED		
SCALE		1:1
AREA mm ²		192.315
PERIMETER mm.		270.36
WEIGHT kg/m		0.519
DRAWING No.	SECTION No.	
P-6033	-	
21150	21150	

1. ALL DIMENSIONS ARE IN mm.
2. ROUND OFF ALL SHARP CORNERS WITH 0.40 mm.
3. TOLERANCES WILL BE AS PER IS:3965-1981 UNLESS OTHERWISE SPECIFIED

PARTY'S NAME: GENERAL CATEGORY, BANGALORE MARKET

PARTY'S DRAWING No.: AS PER DRAWING

ALLOY & TEMPER: 6063 T6

DESCRIPTION: LOUVERS SECTION