

P-5681-1
S1555
21162

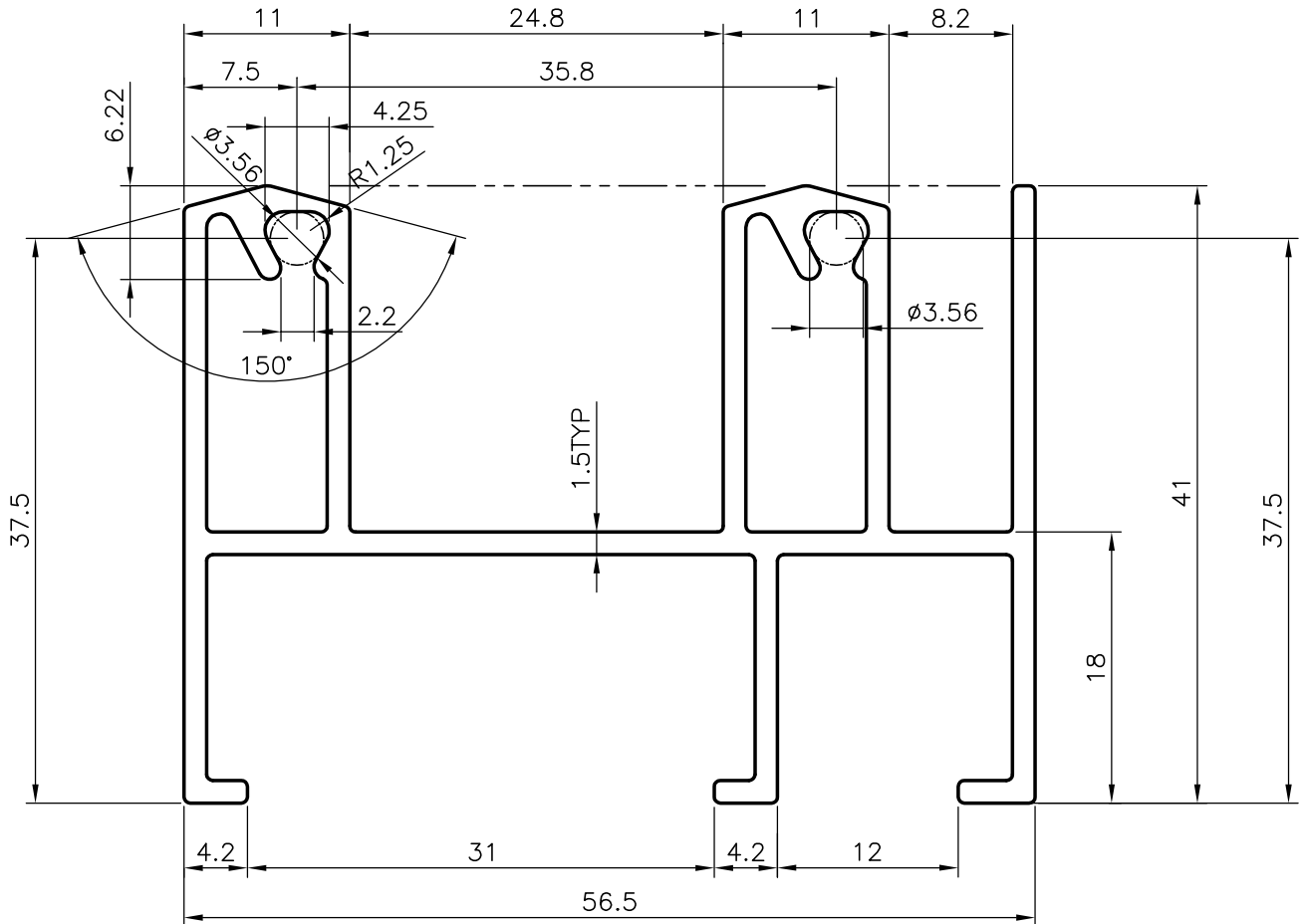

GENERAL WALL THICKNESS = 1.50mm

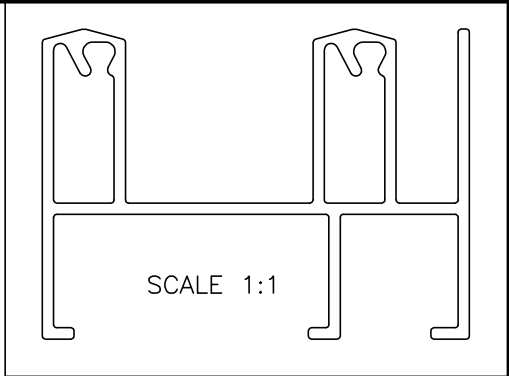

SYMBOL OF QUALITY
AN ISO 9001 COMPANY

JINDAL ALUMINIUM LTD.
BANGALORE-560073 (INDIA)

	NAME	DATE
DRAWN	RAGHAVENDRA	17-07-2005
CHECKED		
APPROVED		

1. ALL DIMENSIONS ARE IN mm.
2. ROUND OFF ALL SHARP CORNERS WITH 0.40 mm.
3. TOLERANCES WILL BE AS PER IS:6477-1983 UNLESS OTHERWISE SPECIFIED

SCALE	2:1
AREA mm ²	377.731
PERIMETER mm.	361.86
WEIGHT kg/m	1.02

PARTY'S NAME	B.L.KASHYAP & SONS LIMITED, BANGALORE
PARTY'S DRAWING No.	AS PER SAMPLE & AS PER REQUIREMENT
ALLOY & TEMPER	HE9 WP
DESCRIPTION	WINDOW OUTER TOP 2 TRACK

DRAWING No.	SECTION No.
P-5681-1	-
S1555	S1555
21162	21162