

P-5684-1

S1557

21164

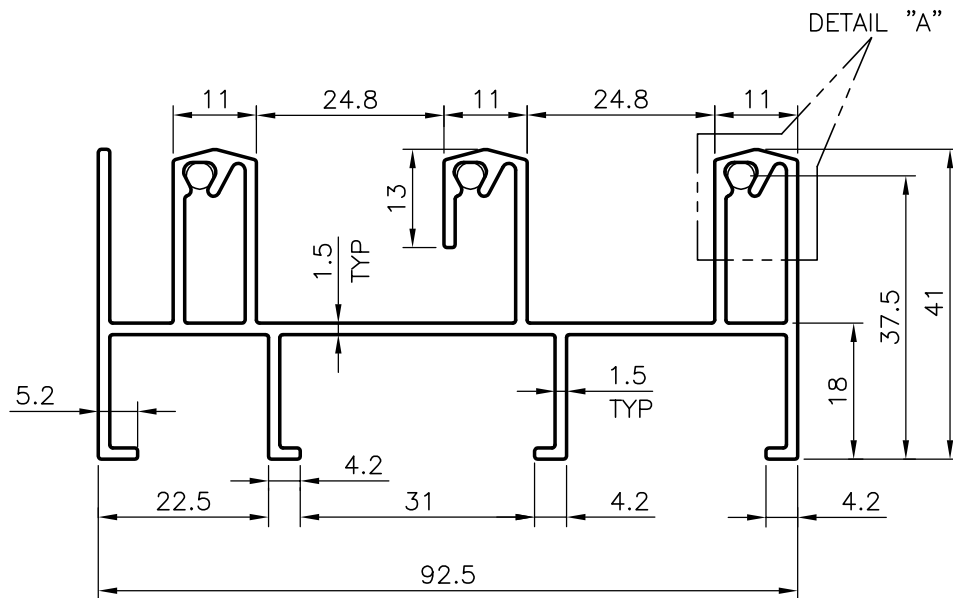
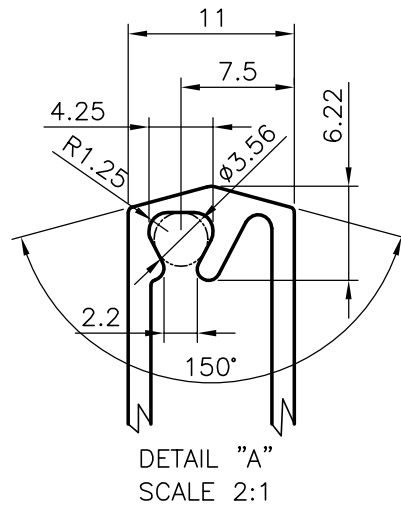

GENERAL WALL THICKNESS = 1.50mm



SYMBOL OF QUALITY
AN ISO 9001 COMPANY

JINDAL ALUMINIUM LTD.
BANGALORE-560073 (INDIA)

	NAME	DATE
DRAWN	J.P.KAUSHIK	19-09-2005
CHECKED		
APPROVED		
SCALE	1:1	
AREA mm ²	530.978	
PERIMETER mm.	562.658	
WEIGHT kg/m	1.434	
DRAWING No.	SECTION No.	
P-5684-1	-	
S1557	S1557(ISSUE-2)	
21164	21164	

1. ALL DIMENSIONS ARE IN mm.
2. ROUND OFF ALL SHARP CORNERS WITH 0.40 mm.
3. TOLERANCES WILL BE AS PER IS:6477-1983 UNLESS OTHERWISE SPECIFIED

PARTY'S NAME	B.L.KASHYAP & SONS LIMITED, BANGALORE
PARTY'S DRAWING No.	AS PER SAMPLE AS PER REQUIREMENT
ALLOY & TEMPER	HE9 WP
DESCRIPTION	WINDOW OUTER TOP 3 TRACK