

P-6845-1

21177

MATCHING SECTION

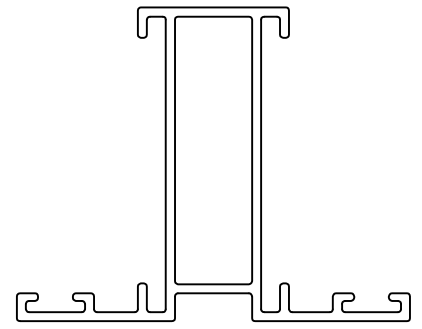
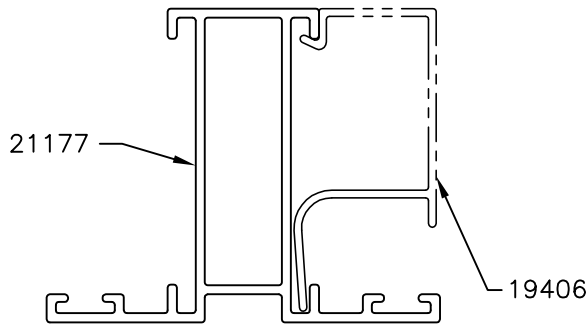

SCALE 1:1

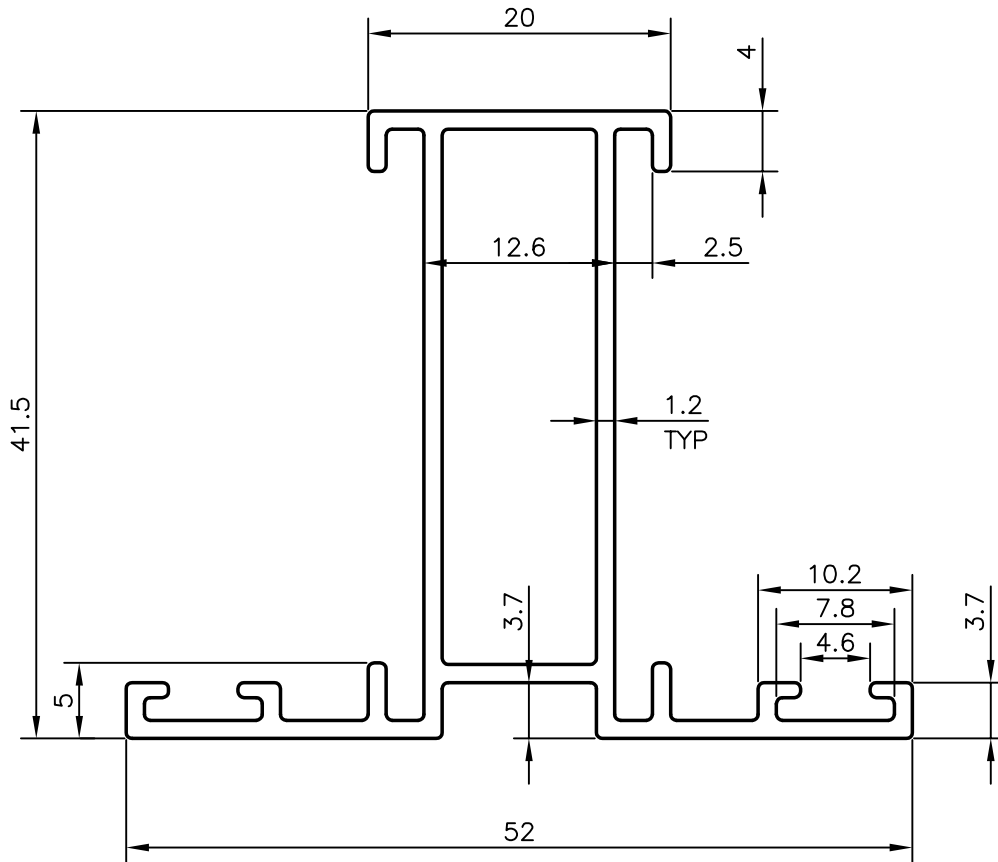

GENERAL WALL THICKNESS = 1.20mm



SYMBOL OF QUALITY  
AN ISO 9001 COMPANY

**JINDAL ALUMINIUM LTD.**  
BANGALORE-560073 (INDIA)

	NAME	DATE
DRAWN	RAGHAVENDRA	30-11-2006
CHECKED		
APPROVED		

1. ALL DIMENSIONS ARE IN mm.
2. ROUND OFF ALL SHARP CORNERS WITH 0.40 mm.
3. TOLERANCES WILL BE AS PER EN12020-2:2001 UNLESS OTHERWISE SPECIFIED

SCALE	2:1
AREA mm <sup>2</sup>	214.48
PERIMETER mm.	260.159
WEIGHT kg/m	0.579

PARTY'S NAME	PRAYOSH ENTERPRISES, UGANDA
PARTY'S DRAWING No.	AS PER DRAWING & AS PER REQUIREMENT
ALLOY & TEMPER	6063 T6
DESCRIPTION	WINDOW SECTION

DRAWING No.	SECTION No.
P-6845-1	-
21177	21177