

P-6850-1
21179

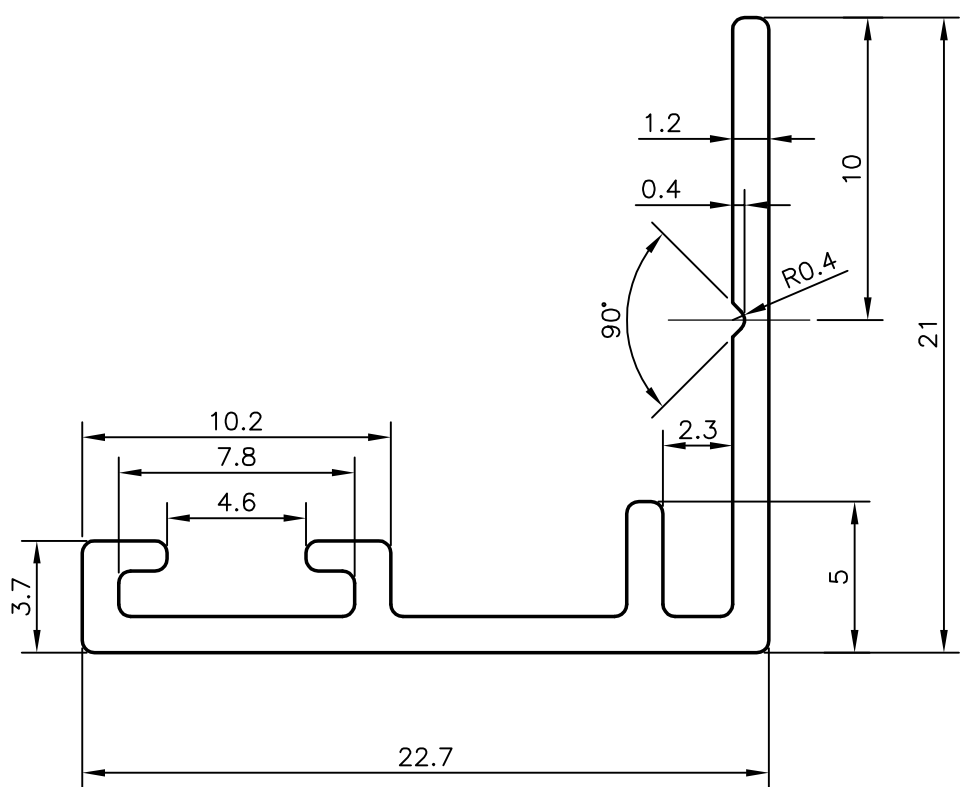

GENERAL WALL THICKNESS = 1.20mm

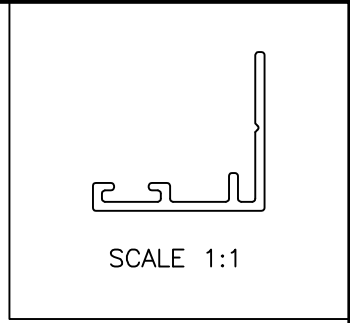
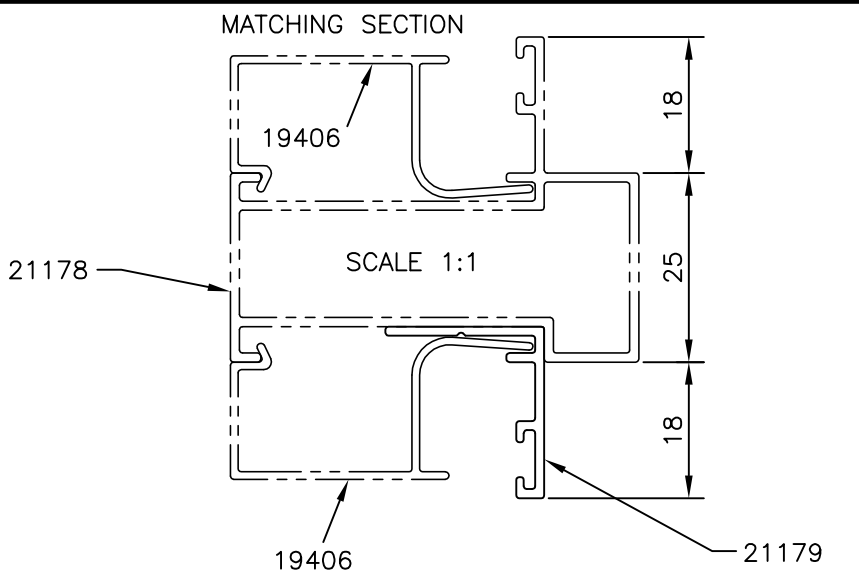

JINDAL ALUMINIUM LTD.
BANGALORE-560073 (INDIA)

	NAME	DATE
DRAWN	RAGHAVENDRA	30-11-2006
CHECKED		
APPROVED		

1. ALL DIMENSIONS ARE IN mm.
2. ROUND OFF ALL SHARP CORNERS WITH 0.40 mm.
3. TOLERANCES WILL BE AS PER EN12020-2:2001 UNLESS OTHERWISE SPECIFIED

SCALE	4:1
AREA mm ²	64.337
PERIMETER mm.	108.263
WEIGHT kg/m	0.174

PARTY'S NAME	PRAYOSH ENTERPRISES, UGANDA
PARTY'S DRAWING No.	AS PER DRAWING & AS PER REQUIREMENT
ALLOY & TEMPER	6063 T6
DESCRIPTION	WINDOW SECTION

DRAWING No.	SECTION No.
P-6850-1	-
21179	21179