

P-7235-2

21210

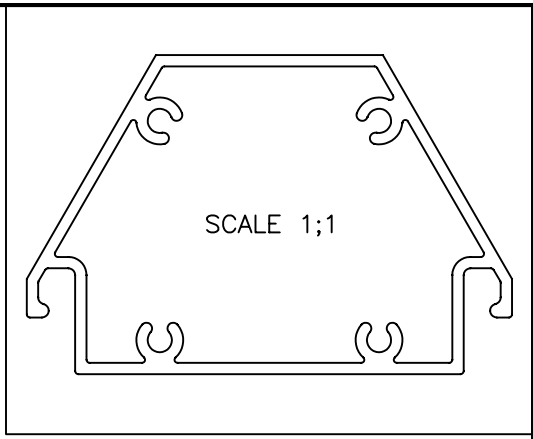

SCALE 1;1

NOTE:-

1. GENERAL WALL THICKNESS = 1.50 mm
2. F = FULL RADIUS (8 PLACES)

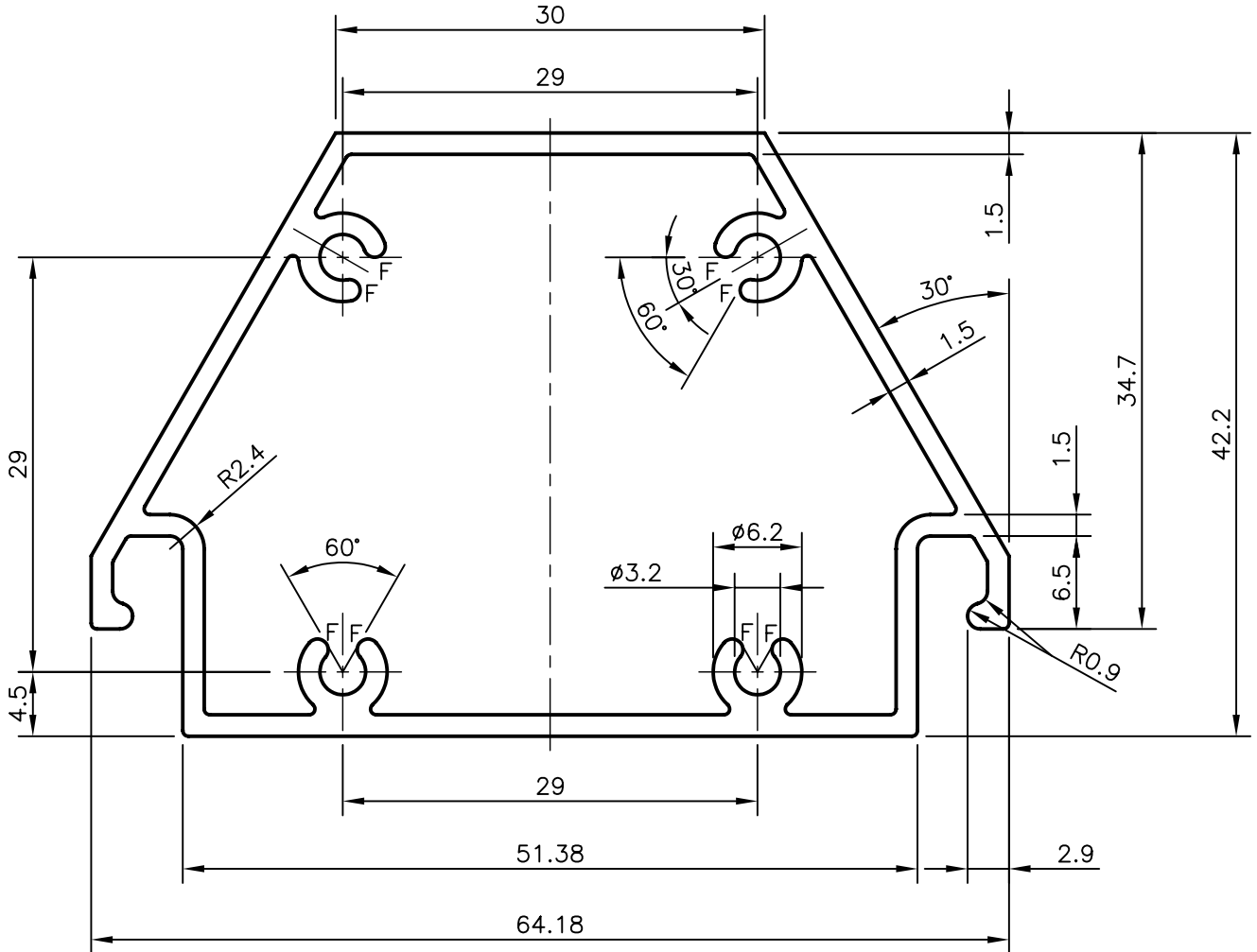

 SYMBOL OF QUALITY AN ISO 9001 COMPANY	JINDAL ALUMINIUM LTD. BANGALORE-560073 (INDIA)	NAME		DATE
		DRAWN	PRASANN.H	02-05-2007
1. ALL DIMENSIONS ARE IN mm. 2. ROUND OFF ALL SHARP CORNERS WITH 0.40 mm. 3. TOLERANCES WILL BE AS PER IS:6477-1983 UNLESS OTHERWISE SPECIFIED		SCALE		2:1
		AREA mm ²		366.094
PARTY'S NAME GENERAL CATEGORY, DELHI MARKET-(RSSB)		PERIMETER mm.		214.025
		WEIGHT kg/m		0.988
PARTY'S DRAWING No. BM-20-130		DRAWING No.		SECTION No.
		P-7235-2		-
ALLOY & TEMPER HE9 WP		21210		21210
		DESCRIPTION		MULLION FOR JALI SHUTTER SECTION