

P-6888-2

21212

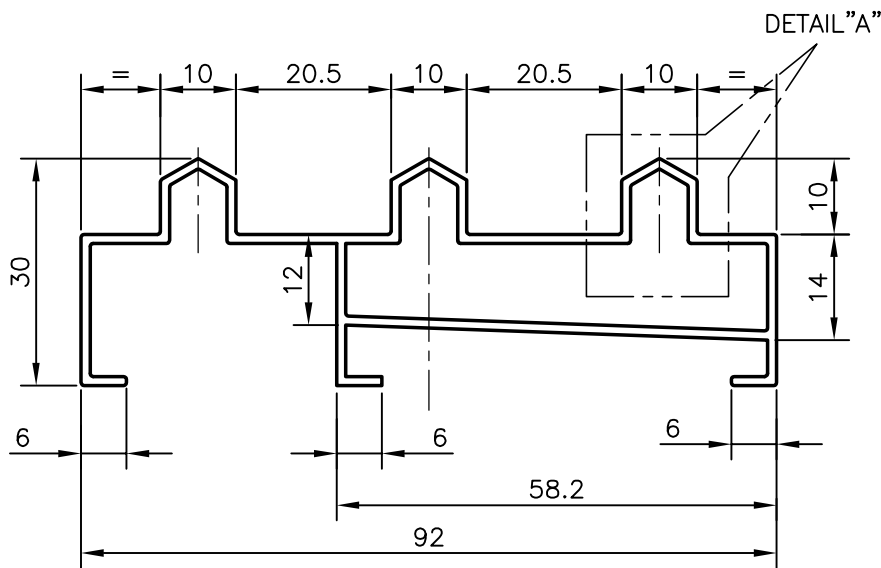

GENERAL WALL THICKNESS = 1.20mm

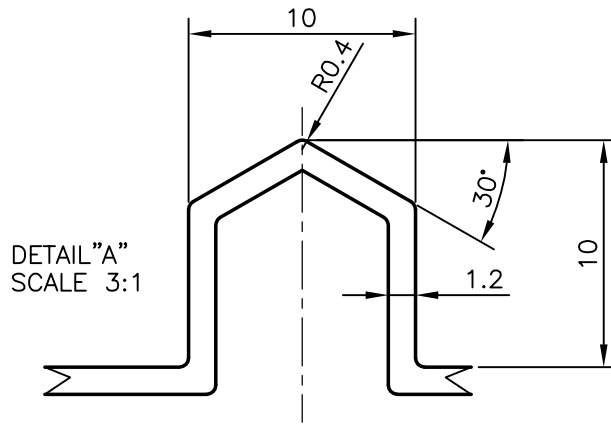

SYMBOL OF QUALITY
AN ISO 9001 COMPANY

JINDAL ALUMINIUM LTD.
BANGALORE-560073 (INDIA)

	NAME	DATE
DRAWN	RAGHAVENDRA	21-12-2006
CHECKED		
APPROVED		
SCALE		1:1
AREA mm ²		320.699
PERIMETER mm.		365.019
WEIGHT kg/m		0.866
DRAWING No.	SECTION No.	
P-6888-2	-	
21212	21212	

1. ALL DIMENSIONS ARE IN mm.
2. ROUND OFF ALL SHARP CORNERS WITH 0.40 mm.
3. TOLERANCES WILL BE AS PER EN12020-2:2001 UNLESS OTHERWISE SPECIFIED

PARTY'S NAME	PRAYOSH ENTERPRISES LTD., UGANDA
PARTY'S DRAWING No.	AS PER REQUIREMENT
ALLOY & TEMPER	6063 T6
DESCRIPTION	WINDOW SECTION