

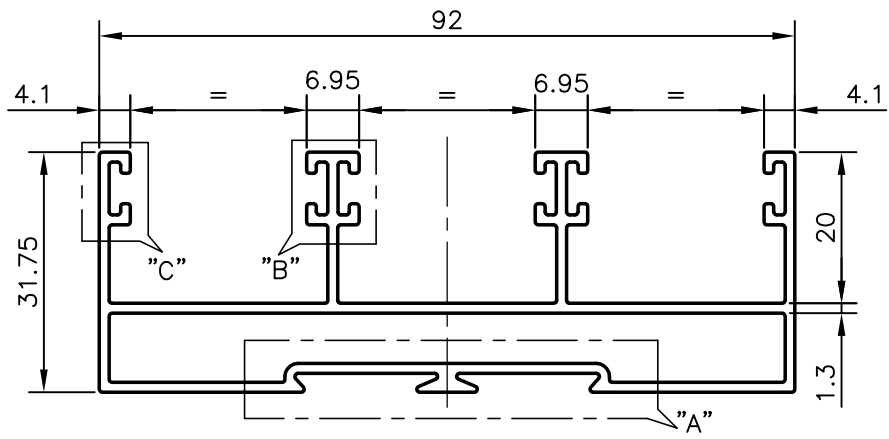

P-7547

21216

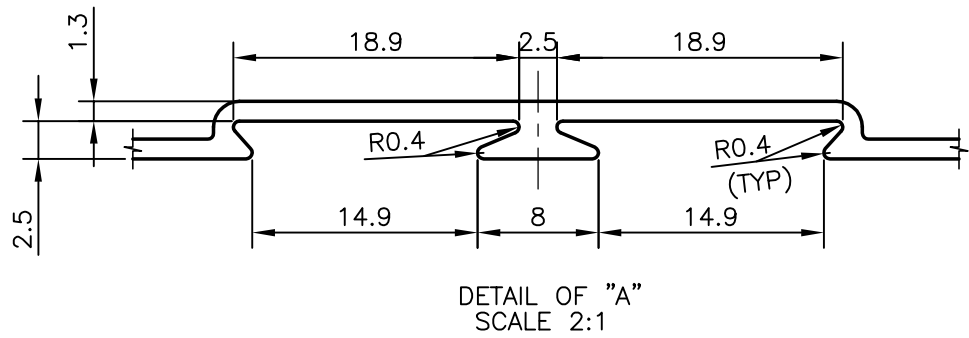
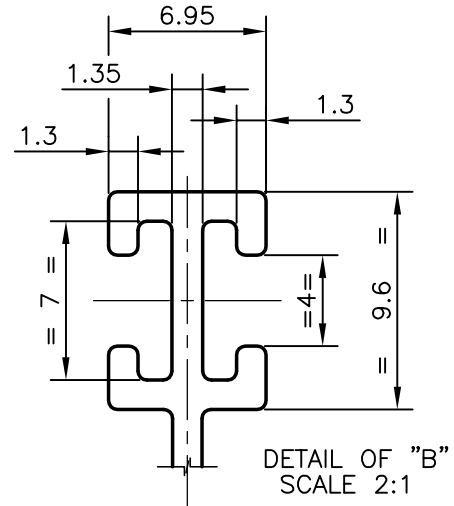
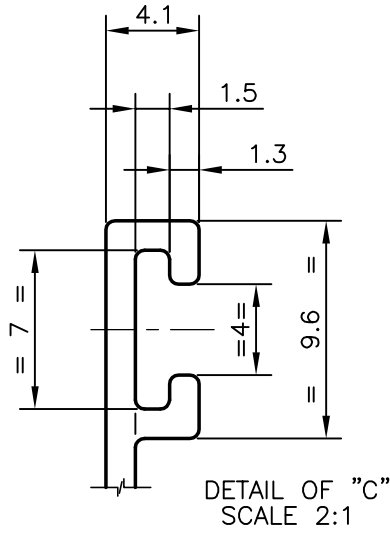

NOTE:-

1. GENERAL WALL THICKNESS = 1.30 mm

 SYMBOL OF QUALITY AN ISO 9001 COMPANY	<b>JINDAL ALUMINIUM LTD.</b> BANGALORE-560073 (INDIA)	NAME	DATE
		DRAWN	PRASANN.H 09-10-2007
		CHECKED	
		APPROVED	
1. ALL DIMENSIONS ARE IN mm. 2. ROUND OFF ALL SHARP CORNERS WITH 0.40 mm. 3. TOLERANCES WILL BE AS PER IS:6477-1983 UNLESS OTHERWISE SPECIFIED		SCALE	1:1
		AREA mm <sup>2</sup>	456.608
		PERIMETER mm.	478.77
PARTY'S NAME	NAGARJUNA CONSTRUCTION CO. LTD., RAANCHI	WEIGHT kg/m	1.233
PARTY'S DRAWING No.	ITEM NO-3 AS PER DRAWING	DRAWING No.	P-7547
ALLOY & TEMPER	HE9 WP	SECTION No.	-
DESCRIPTION	WINDOW SECTION-TOP RAIL		21216