

P-7966-1

21236

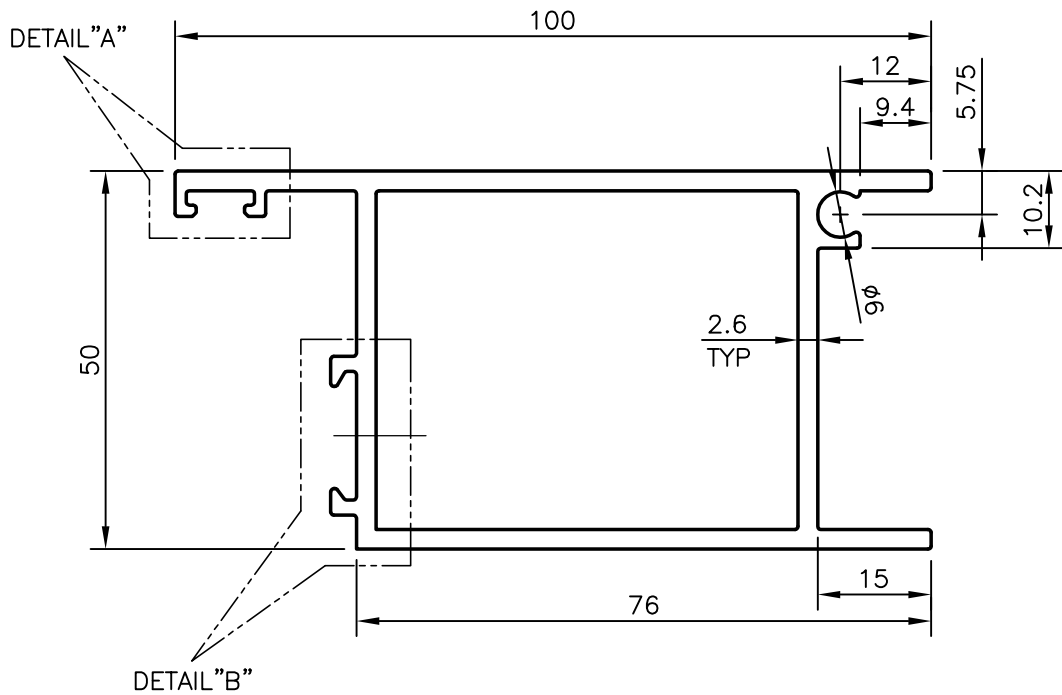

GENERAL WALL THICKNESS = 2.60mm

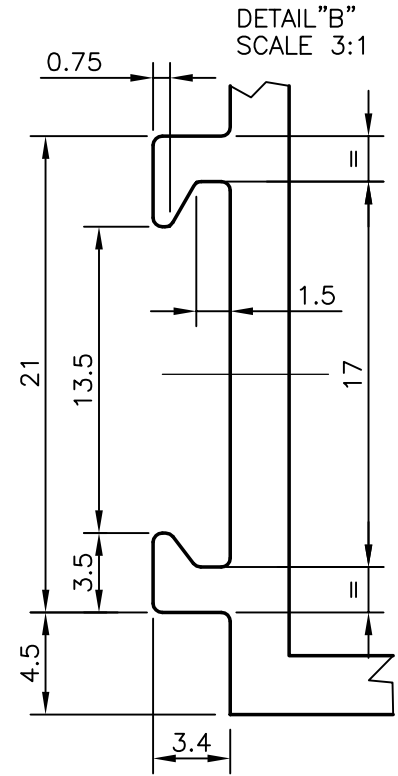
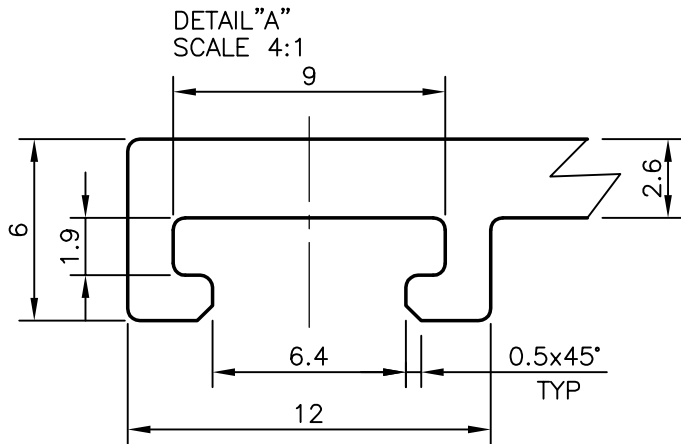

SYMBOL OF QUALITY
AN ISO 9001 COMPANY

JINDAL ALUMINIUM LTD.
BANGALORE-560073 (INDIA)

	NAME	DATE
DRAWN	RAGHAVENDRA	05-03-2008
CHECKED		
APPROVED		

1. ALL DIMENSIONS ARE IN mm.
2. ROUND OFF ALL SHARP CORNERS WITH 0.40 mm.
3. TOLERANCES WILL BE AS PER IS:6477-1983 UNLESS OTHERWISE SPECIFIED

SCALE	1:1
AREA mm ²	737.187
PERIMETER mm.	372.505
WEIGHT kg/m	1.99

PARTY'S NAME P.K.ALUINFRA PVT LTD., NEW DELHI

DRAWING No. SECTION No.

PARTY'S DRAWING No. PKAI/DW-007

P-7966-1

-

ALLOY & TEMPER 6063 T6

21236

21236

DESCRIPTION BOTTOM RAIL SECTION