

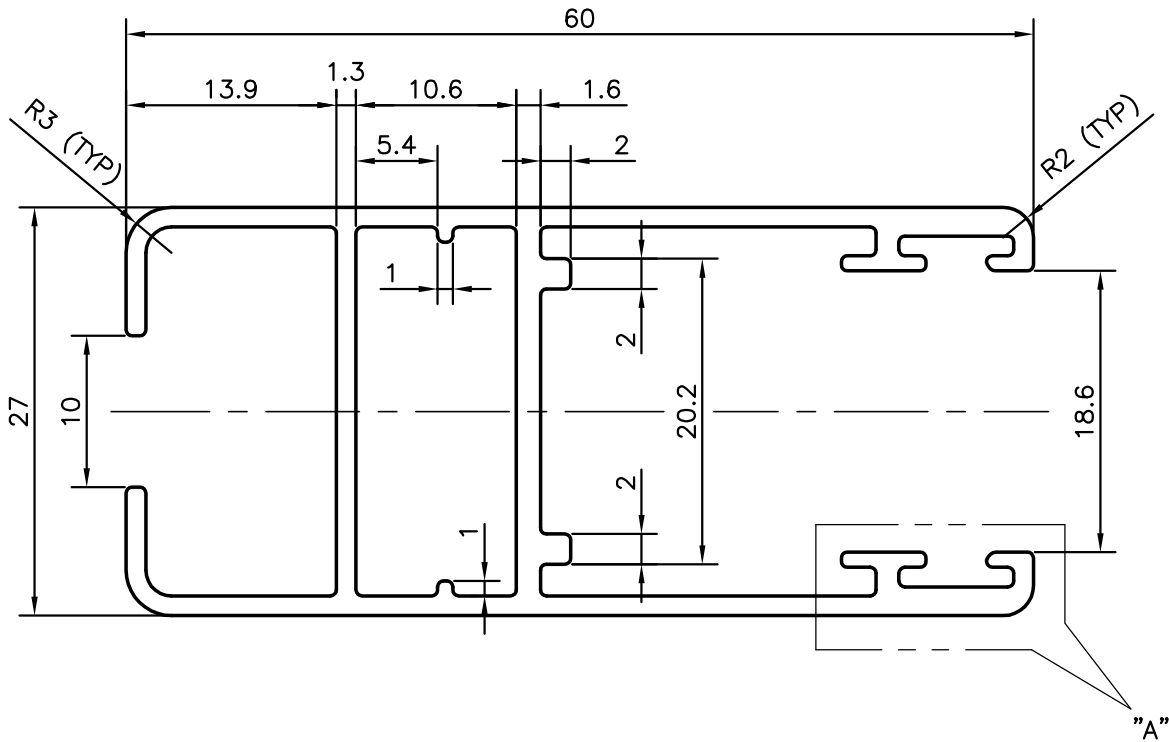

P-8161-1
21241
X950
21241

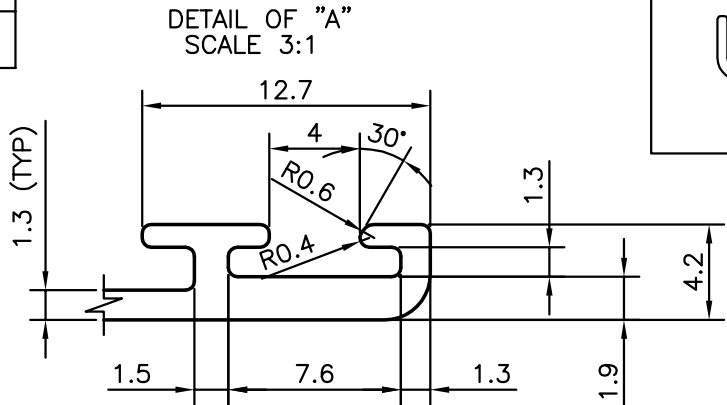
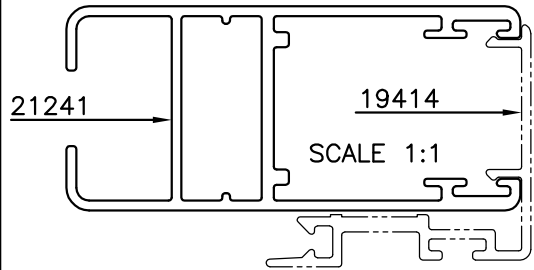

UNSPECIFIED WALL THICKNESS = 1.30 mm

 SYMBOL OF QUALITY AN ISO 9001 COMPANY	<b>JINDAL ALUMINIUM LTD.</b> BANGALORE-560073 (INDIA)	DRAWN	NAME	DATE
		CHECKED	PRASANNA.H	26-04-2008
1. ALL DIMENSIONS ARE IN mm. 2. ROUND OFF ALL SHARP CORNERS WITH 0.40 mm. 3. TOLERANCES WILL BE AS PER IS:6477-1983 UNLESS OTHERWISE SPECIFIED		APPROVED		
		SCALE		2:1
PARTY'S NAME RANA ALUMINIUM & HARDWARE, MUMBAI		AREA mm <sup>2</sup>		288.257
		PERIMETER mm.		335.026
PARTY'S DRAWING No. AS PER DRAWING		WEIGHT kg/m		0.778
		DRAWING No.		
ALLOY & TEMPER HE9 WP		SECTION No.		
		P-8161-1		-
DESCRIPTION WINDOW SECTION		21241		21241
		X950		X950
		21241		21241