

P-8252-2

21248

DETAIL OF "C"
SCALE 3:1

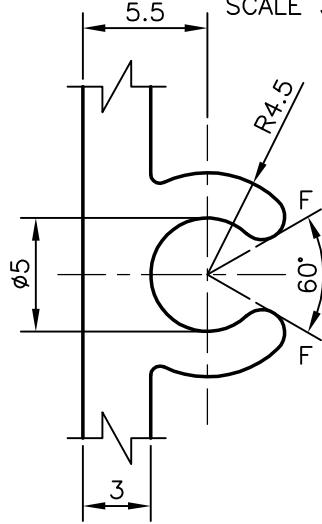

DETAIL OF "B"
SCALE 3:1

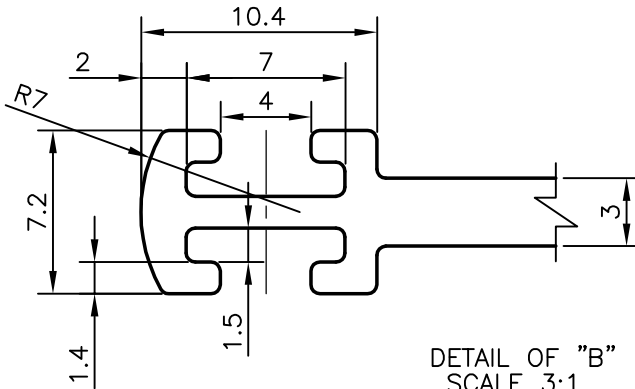

DETAIL OF "A"
SCALE 3:1

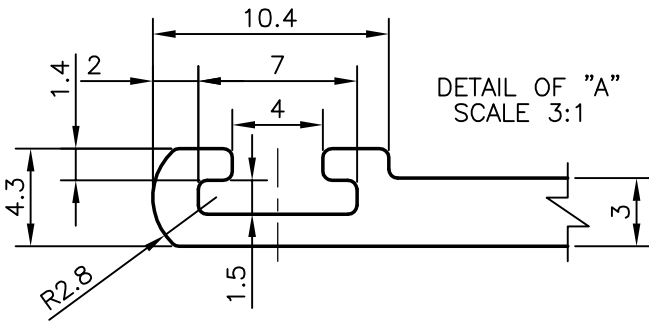

UNSPECIFIED WALL THICKNESS = 3.0 mm
F = FULL RADIUS (8 PLACES)

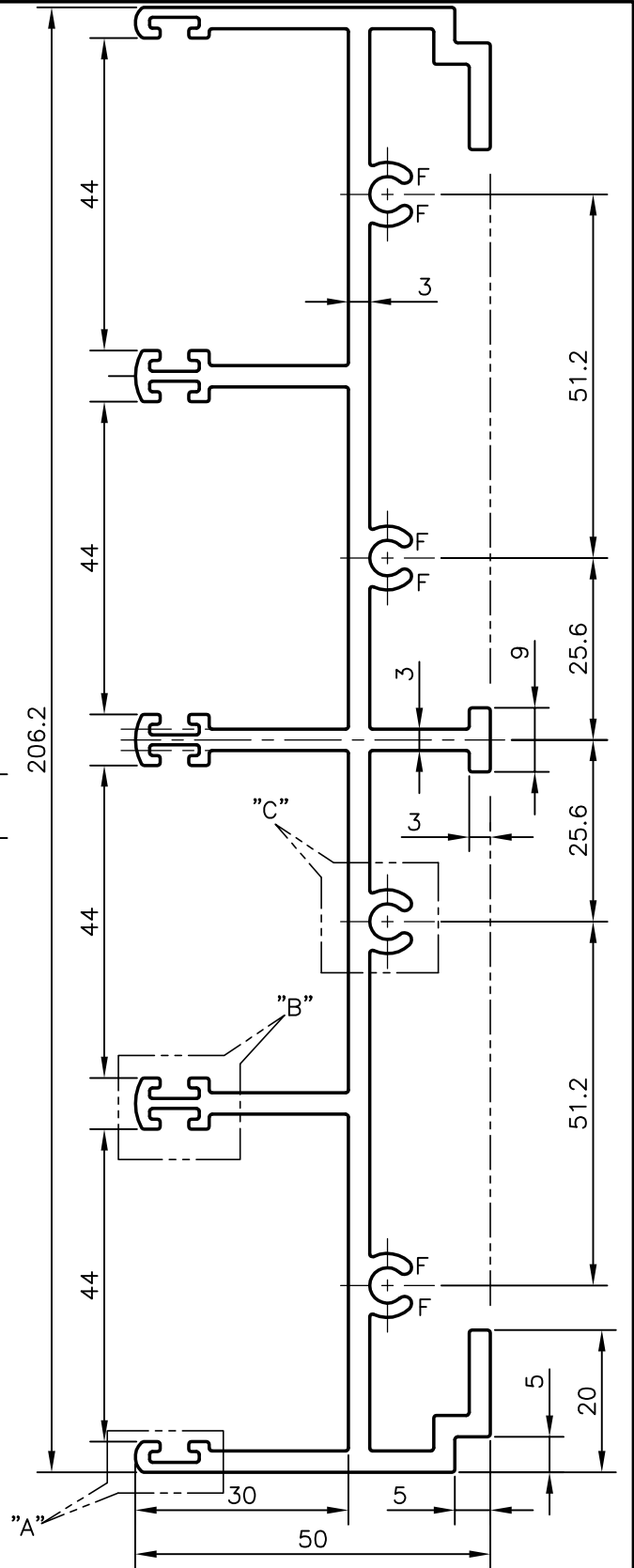

SYMBOL OF QUALITY
AN ISO 9001 COMPANY

JINDAL ALUMINIUM LTD.
BANGALORE-560073 (INDIA)

	NAME	DATE
DRAWN	PRASANNA.H	16-05-2008
CHECKED		
APPROVED		

1. ALL DIMENSIONS ARE IN mm.
2. ROUND OFF ALL SHARP CORNERS WITH 0.40 mm.
3. TOLERANCES WILL BE AS PER IS:3965-1981 UNLESS OTHERWISE SPECIFIED

SCALE	1:1
AREA mm ²	1463.024
PERIMETER mm.	1083.504
WEIGHT kg/m	3.950

PARTY'S NAME	AMMYS ALUMINIUM, MUMBAI
PARTY'S DRAWING No.	AAE-06
ALLOY & TEMPER	6063 T5
DESCRIPTION	WINDOW SECTION

DRAWING No.	SECTION No.
P-8252-2	-
21248	21248