

P-8656-1

21253

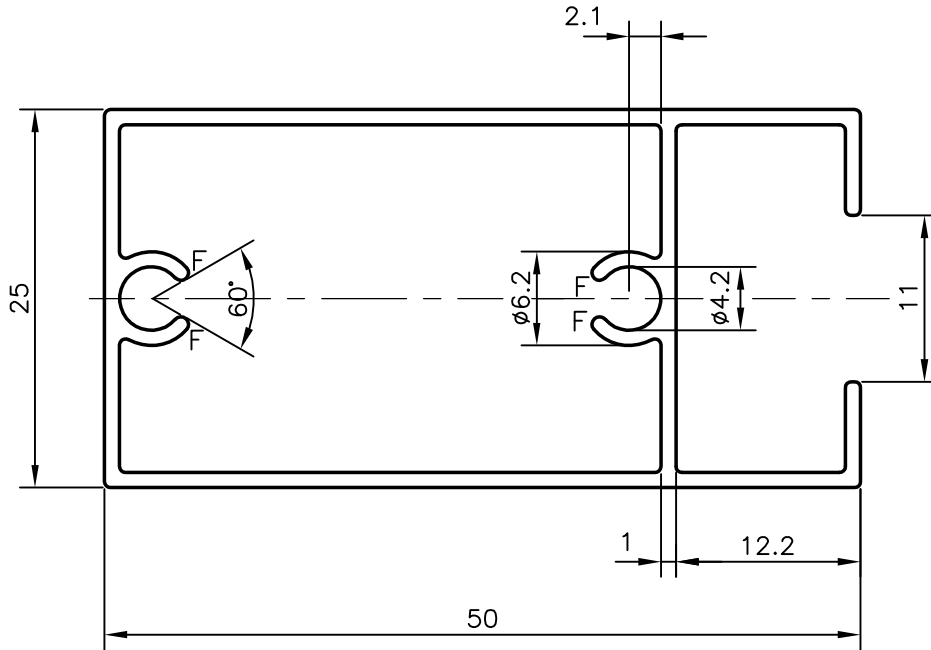
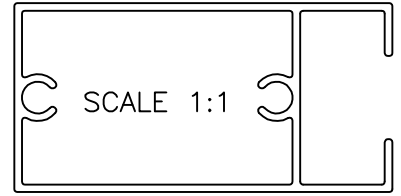

NOTE:-

1. GENERAL WALL THICKNESS = 1.0 mm
2. F = FULL RADIUS (4 PLACES)



SYMBOL OF QUALITY
AN ISO 9001 COMPANY

JINDAL ALUMINIUM LTD.
BANGALORE-560073 (INDIA)

	NAME	DATE
DRAWN	ABHARANI	01-10-2008
CHECKED		
APPROVED		

1. ALL DIMENSIONS ARE IN mm.
2. ROUND OFF ALL SHARP CORNERS WITH 0.40 mm.
3. TOLERANCES WILL BE AS PER IS:6477-1983 UNLESS OTHERWISE SPECIFIED

SCALE	2:1
AREA mm ²	178.975
PERIMETER mm.	196.34
WEIGHT kg/m	0.483

PARTY'S NAME	GENERAL CATEGORY, AHMEDABAD MARKET
PARTY'S DRAWING No.	LIGHTER OF SECTION NO. 20707
ALLOY & TEMPER	HE9 WP
DESCRIPTION	WINDOW SECTION

DRAWING No.	SECTION No.
P-8656-1	-
21253	21253