

P-6448

X608

21258

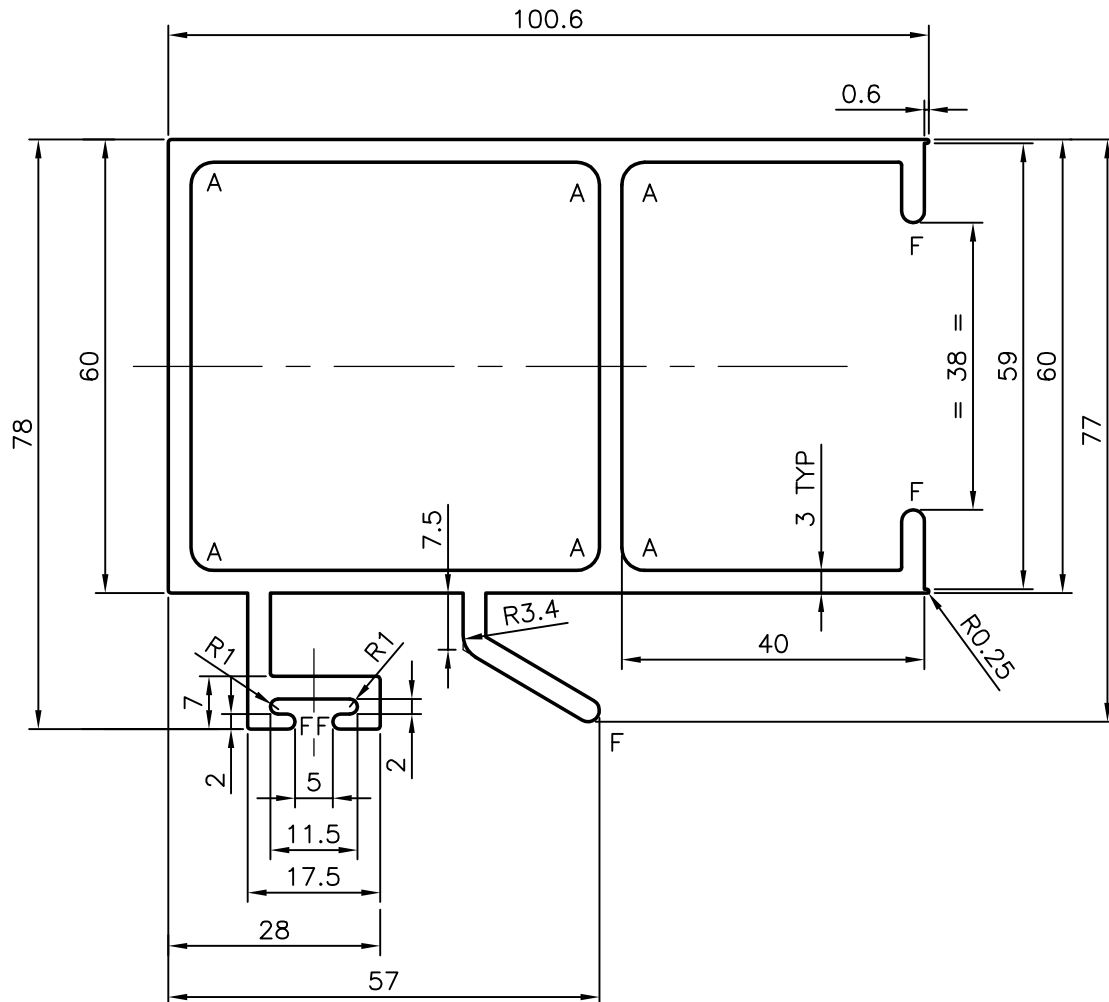

GENERAL WALL THICKNESS = 3 mm

F = FULL RADIUS (5 PLACES)

A = R3 (6 PLACES)



SYMBOL OF QUALITY
AN ISO 9001 COMPANY

JINDAL ALUMINIUM LTD.
BANGALORE-560073 (INDIA)

| | NAME | DATE |
|----------|-------------|------------|
| DRAWN | RAGHAVENDRA | 31-05-2006 |
| CHECKED | | |
| APPROVED | | |

1. ALL DIMENSIONS ARE IN mm.
2. ROUND OFF ALL SHARP CORNERS WITH 0.40 mm.
3. TOLERANCES WILL BE AS PER IS:6477-1983 UNLESS OTHERWISE SPECIFIED

| | |
|----------------------|----------|
| SCALE | 1:1 |
| AREA mm ² | 1179.757 |
| PERIMETER mm. | 559.498 |
| WEIGHT kg/m | 3.185 |

PARTY'S NAME: K. RAHEJA UNIVERSAL, MUMBAI

PARTY'S DRAWING No.: FUSION/ALT/DIE/003

ALLOY & TEMPER: HE9 WP

DESCRIPTION: WINDOW SECTION

| DRAWING No. | SECTION No. |
|-------------|-------------|
| P-6448 | - |
| X608 | X608 |
| 21258 | 21258 |