

P-6083-1

X501

21261

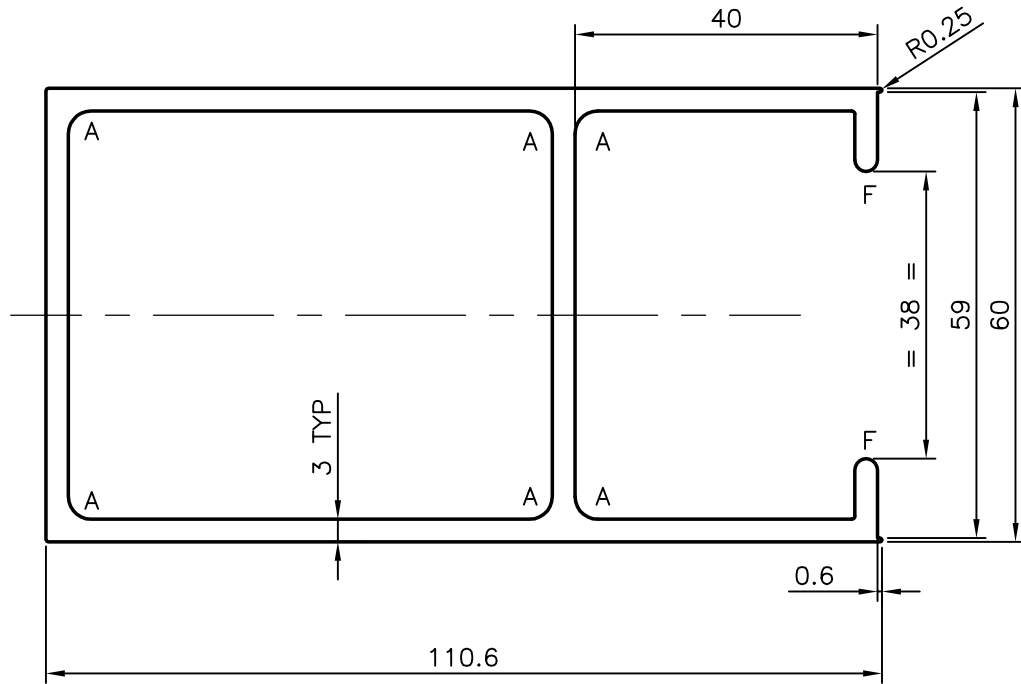

GENERAL WALL THICKNESS = 3 mm

F = FULL RADIUS (2 PLACES)

A = R3 (6 PLACES)



SYMBOL OF QUALITY
AN ISO 9001 COMPANY

JINDAL ALUMINIUM LTD.
BANGALORE-560073 (INDIA)

	NAME	DATE
DRAWN	MAHALINGAPPA	04-01-2006
CHECKED		
APPROVED		

1. ALL DIMENSIONS ARE IN mm.
2. ROUND OFF ALL SHARP CORNERS WITH 0.40 mm.
3. TOLERANCES WILL BE AS PER IS:6477-1983 UNLESS OTHERWISE SPECIFIED

SCALE	1:1
AREA mm ²	1042.203
PERIMETER mm.	448.134
WEIGHT kg/m	2.814

PARTY'S NAME	AMMYS ALUMINIUM, MUMBAI
PARTY'S DRAWING No.	AS PER SKETCH & REQUIREMENT
ALLOY & TEMPER	HE9 WP
DESCRIPTION	HANDLE SECTION WINDOW

DRAWING No.	SECTION No.
P-6083-1	-
X501	X501
21261	21261