

P-6086

X504

21264

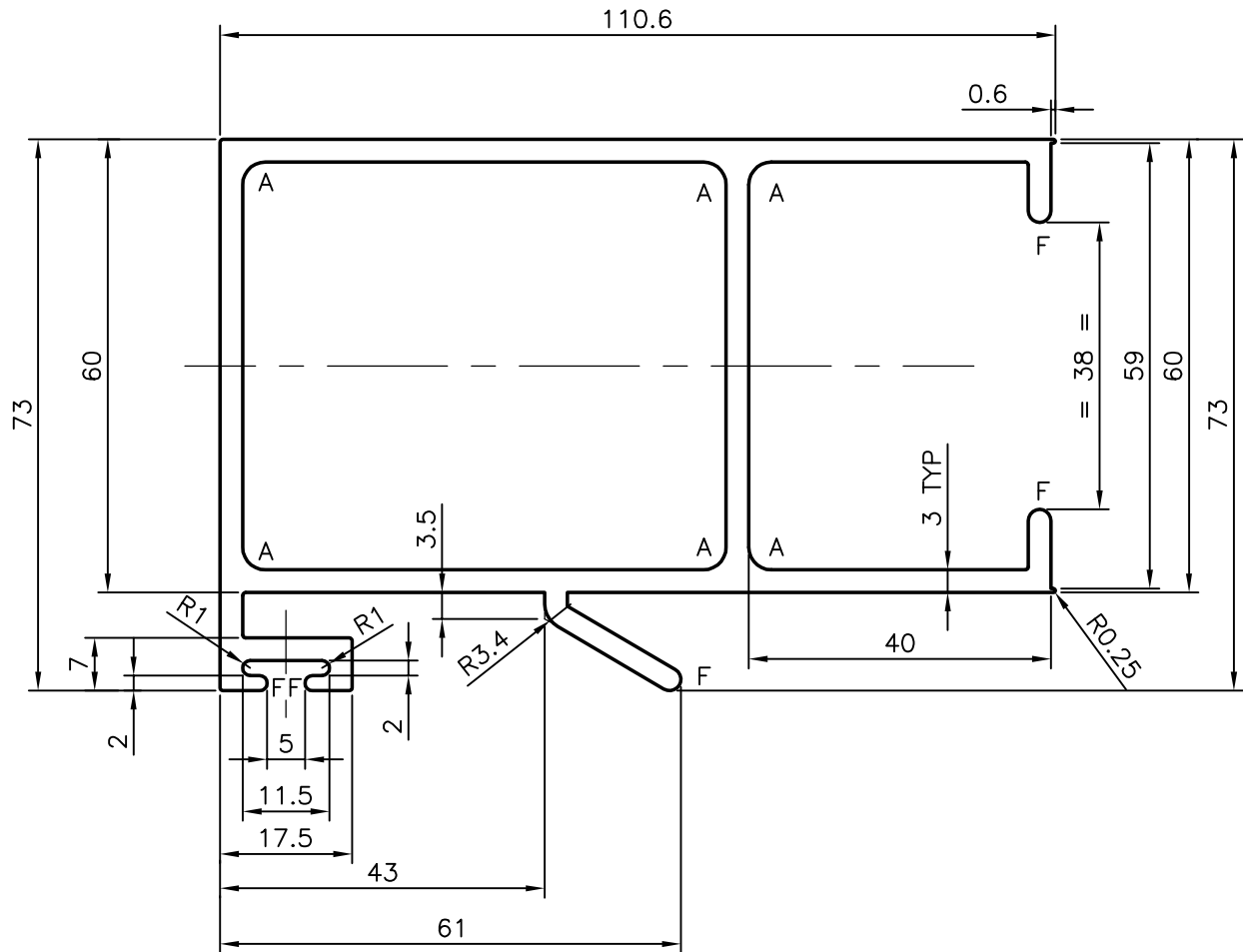

GENERAL WALL THICKNESS = 3 mm

F = FULL RADIUS (5 PLACES)

A = R3 (6 PLACES)

ISSUE-2 - DIMENSION CHANGED FROM
 7.5 TO 3.5 mm
 78 TO 73 mm
 77 TO 73 mm



SYMBOL OF QUALITY
 AN ISO 9001 COMPANY

JINDAL ALUMINIUM LTD.
 BANGALORE-560073 (INDIA)

	NAME	DATE
DRAWN	MAHALINGAPPA	15-04-2006
CHECKED		
APPROVED		
SCALE		1:1
AREA mm ²		1212.826
PERIMETER mm.		561.498
WEIGHT kg/m		3.275
DRAWING No.	SECTION No.	
P-6086	-	
X504	X504-ISSUE-2	
21264	21264	

1. ALL DIMENSIONS ARE IN mm. 2. ROUND OFF ALL SHARP CORNERS WITH 0.40 mm. 3. TOLERANCES WILL BE AS PER IS:6477-1983 UNLESS OTHERWISE SPECIFIED	
PARTY'S NAME	AMMYS ALUMINIUM, MUMBAI
PARTY'S DRAWING No.	AS PER SKETCH & REQUIREMENT
ALLOY & TEMPER	HE9 WP
DESCRIPTION	WINDOW SECTION