

P-6443

X601

21266

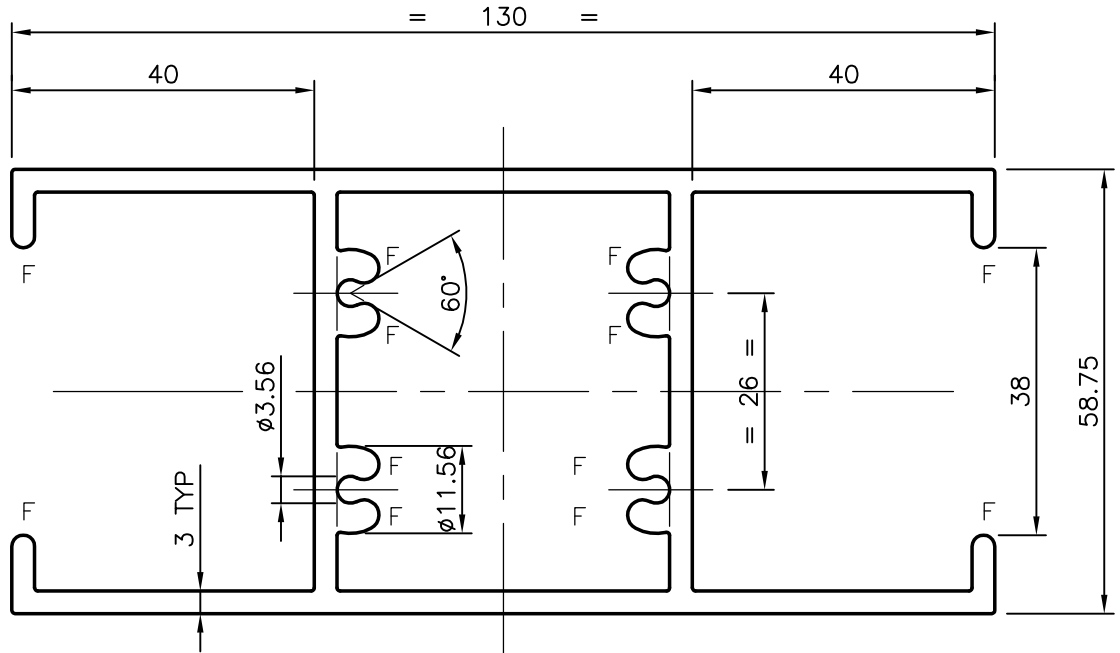

GENERAL WALL THICKNESS = 3 mm
 F = FULL RADIUS (12 PLACES)



SYMBOL OF QUALITY
 AN ISO 9001 COMPANY

JINDAL ALUMINIUM LTD.
 BANGALORE-560073 (INDIA)

	NAME	DATE
DRAWN	MAHALINGAPPA	31-05-2006
CHECKED		
APPROVED		
SCALE		1:1
AREA mm ²		1352.472
PERIMETER mm.		589.289
WEIGHT kg/m		3.652
DRAWING No.		SECTION No.
P-6443		-
X601		X601
21266		21266

1. ALL DIMENSIONS ARE IN mm.
2. ROUND OFF ALL SHARP CORNERS WITH 0.40 mm.
3. TOLERANCES WILL BE AS PER IS:6477-1983 UNLESS OTHERWISE SPECIFIED

PARTY'S NAME	K. RAHEJA UNIVERSAL, MUMBAI
PARTY'S DRAWING No.	FUSION/ALT/DIE/001
ALLOY & TEMPER	HE9 WP
DESCRIPTION	TOP & BOTTOM WINDOW SECTION