

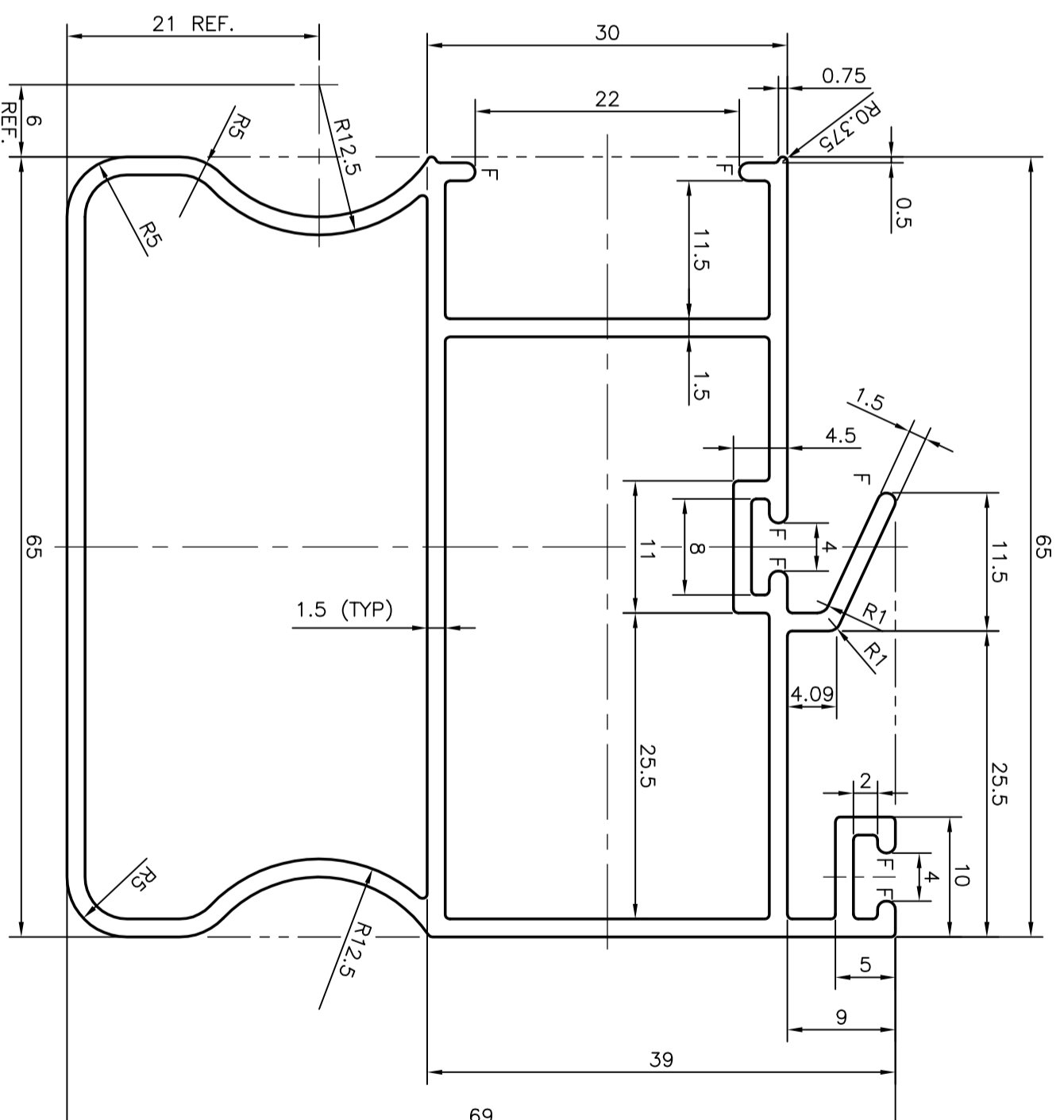

P-8829-1

21273

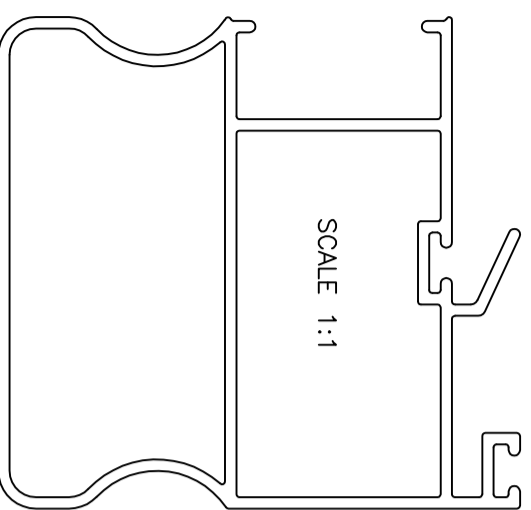

GENERAL WALL THICKNESS = 1.50 mm  
F = FULL RADIUS (7 PLACES)



 <b>JINDAL ALUMINIUM LTD.</b> BANGALORE-560073 (INDIA)		NAME	DATE
		DRAWN PRASANNA.H	24-11-2008
1. ALL DIMENSIONS ARE IN mm. 2. ROUND OFF ALL SHARP CORNERS WITH 0.40 mm. 3. TOLERANCES WILL BE AS PER IS:6477-1983 UNLESS OTHERWISE SPECIFIED		CHECKED	
		APPROVED	
PARTY'S NAME		GENERAL CATEGORY, MUMBAI MARKET	
PARTY'S DRAWING No.		AS PER DRAWING	
ALLOY & TEMPER		HE9 WP	
DESCRIPTION		WINDOW SECTION	
SCALE		2:1	
AREA mm <sup>2</sup>		541.448	
PERIMETER mm.		372.842	
WEIGHT kg/m		1.462	
DRAWING No.		SECTION No.	
P-8829-1		-	
21273		21273	