

P-9021-1

21288

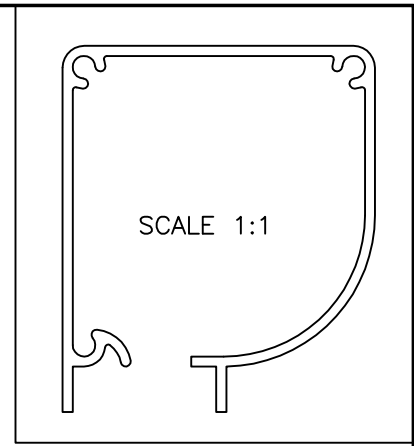

DETAIL "A"

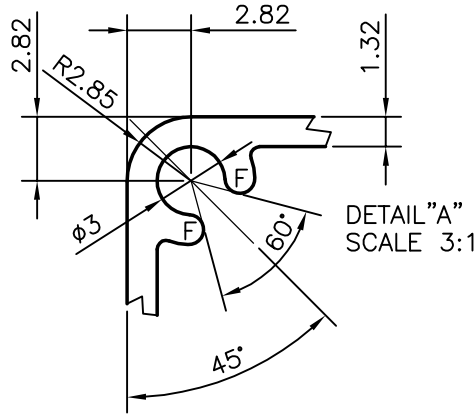
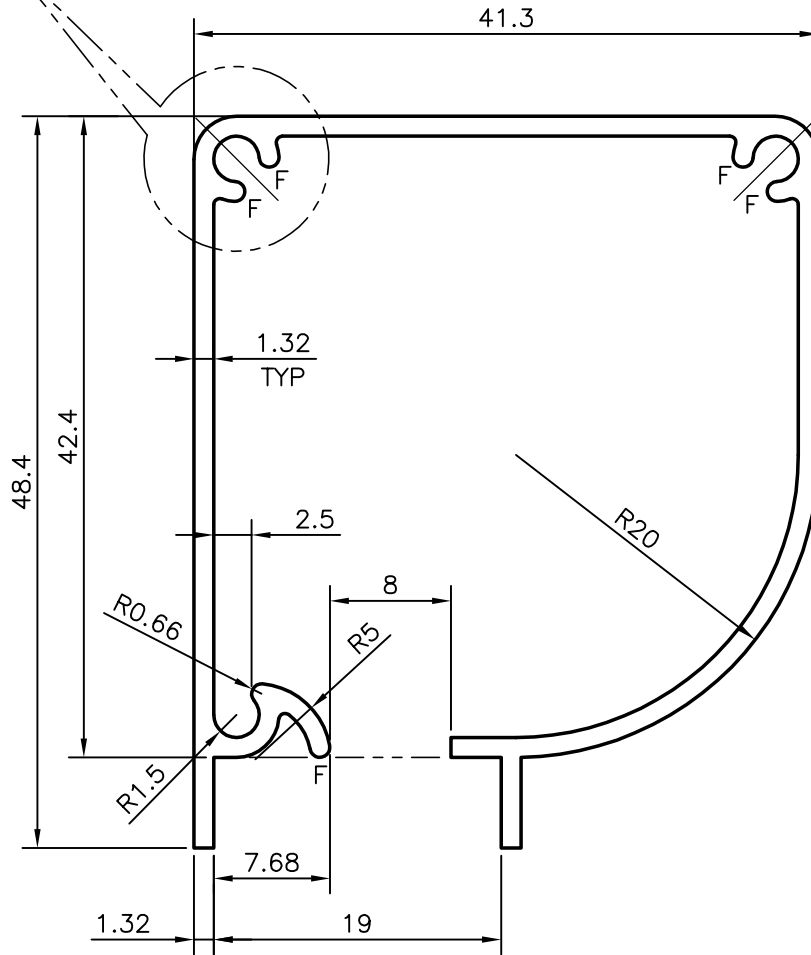

GENERAL WALL THICKNESS = 1.32 mm
 F = FULL RADIUS (5 PLACES)



SYMBOL OF QUALITY
 AN ISO 9001 COMPANY

JINDAL ALUMINIUM LTD.
 BANGALORE-560073 (INDIA)

	NAME	DATE
DRAWN	RAGHAVENDRA	09-02-2009

CHECKED		
---------	--	--

APPROVED		
----------	--	--

SCALE	2:1
-------	-----

AREA mm ²	223.911
----------------------	---------

PERIMETER mm.	333.281
---------------	---------

WEIGHT kg/m	0.605
-------------	-------

DRAWING No.	SECTION No.
P-9021-1	
21288	21288

--	--

--	--

1. ALL DIMENSIONS ARE IN mm.
2. ROUND OFF ALL SHARP CORNERS WITH 0.40 mm.
3. TOLERANCES WILL BE AS PER IS:3965-1981 UNLESS OTHERWISE SPECIFIED

PARTY'S NAME VESKHA INTERIOR, KERALA

PARTY'S DRAWING No. AS PER DRAWING

ALLOY & TEMPER HE9 WP

DESCRIPTION WINDOW SECTION