

P-9916

21312

TYPICAL DETAIL

DETAIL "A"
SCALE 3:1

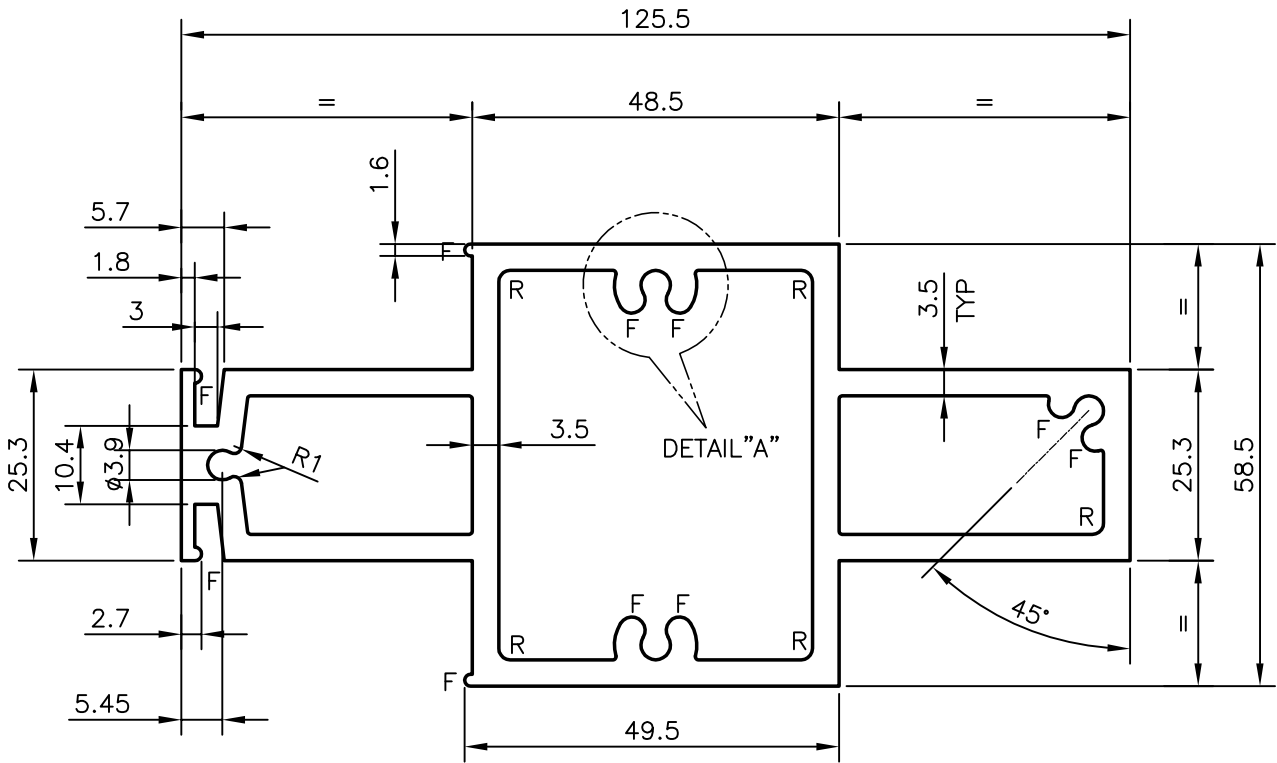
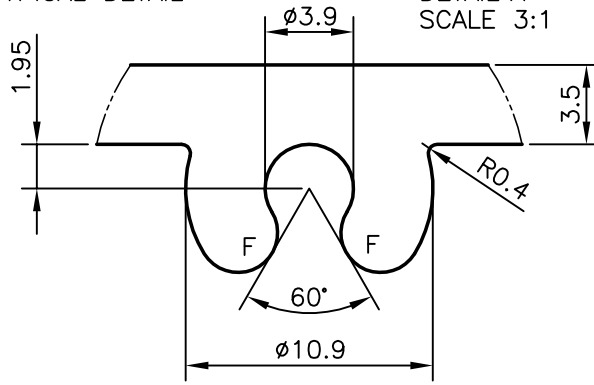

GENERAL WALL THICKNESS = 3.5mm
R = 1.5mm RADIUS (5 PLACES)
F = FULL RADIUS (10 PLACES)



SYMBOL OF QUALITY
AN ISO 9001 COMPANY

JINDAL ALUMINIUM LTD.
BANGALORE-560073 (INDIA)

	NAME	DATE
DRAWN	RAGHAVENDRA	22-03-2010
CHECKED		
APPROVED	S.S.GARG	27-03-2010
SCALE		1:1
AREA mm ²		1493.578
PERIMETER mm.		400.79
WEIGHT kg/m		4.033
DRAWING No.	SECTION No.	
P-9916	-	
21312	21312	

1. ALL DIMENSIONS ARE IN mm.
2. ROUND OFF ALL SHARP CORNERS WITH 0.40 mm.
3. TOLERANCES WILL BE AS PER IS:6477-1983, UNLESS OTHERWISE SPECIFIED

PARTY'S NAME	GENERAL CATEGORY, DELHI MARKET
PARTY'S DRAWING No.	AS PER REQUIREMENT (20996)
ALLOY & TEMPER	6063 T6
DESCRIPTION/END USE	WINDOW CENTRE MULLION