

P-9557

S2345

21315

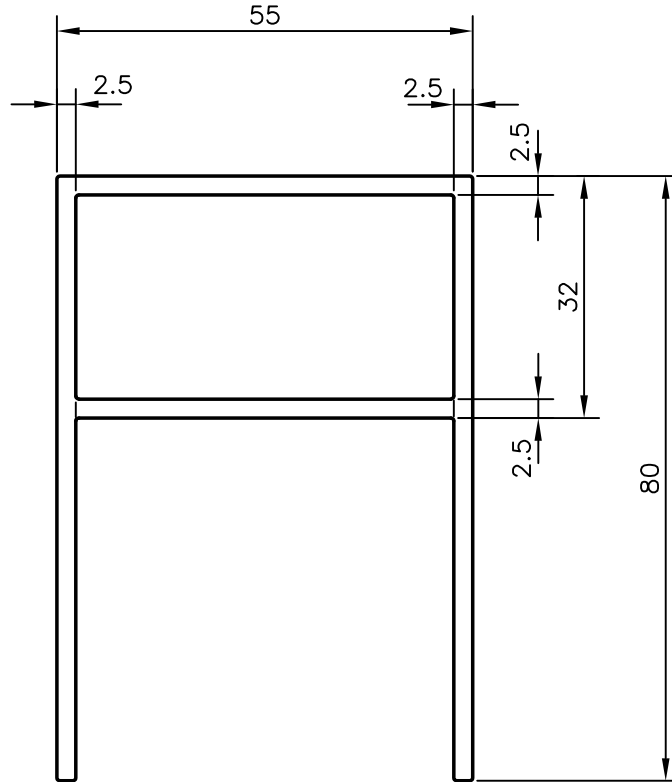

SYMBOL OF QUALITY
AN ISO 9001 COMPANY

JINDAL ALUMINIUM LTD.
BANGALORE-560073 (INDIA)

	NAME	DATE
DRAWN	J.P.KAUSHIK	14-10-2009
CHECKED		
APPROVED		

1. ALL DIMENSIONS ARE IN mm.
2. ROUND OFF ALL SHARP CORNERS WITH 0.40 mm.
3. TOLERANCES WILL BE AS PER IS:6477-1983 UNLESS OTHERWISE SPECIFIED

SCALE	1:1
AREA mm ²	650
PERIMETER mm.	364.627
WEIGHT kg/m	1.755

PARTY'S NAME SP FABRICATORS PVT. LTD., NAVI MUMBAI

DRAWING No.	SECTION No.
P-9557	-
S2345	S2345
21315	21315

PARTY'S DRAWING No. AL-632

ALLOY & TEMPER 6063 T6

DESCRIPTION RUNNER PROFILE