

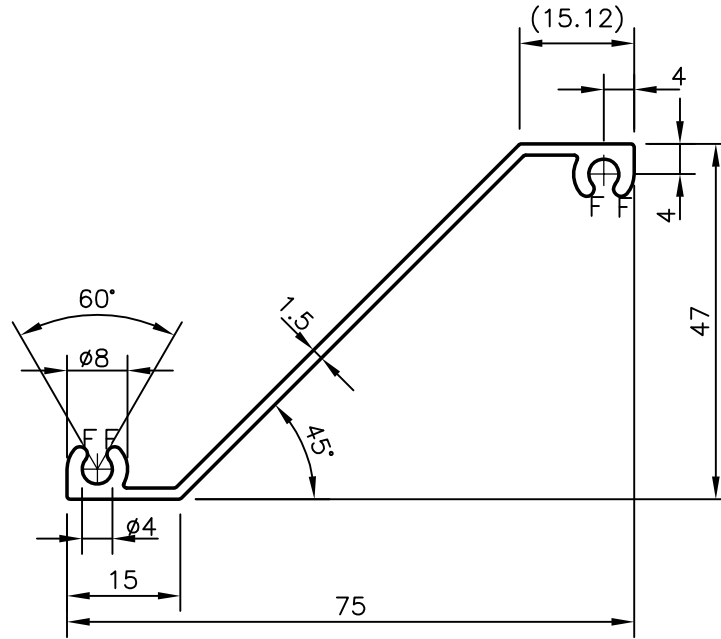

P-8969-1

21318



NOTE:-

1. F = FULL RADIUS (4 PLACE)
2. GENERAL WALL THICKNESS = 1.50 mm

 SYMBOL OF QUALITY AN ISO 9001 COMPANY	<b>JINDAL ALUMINIUM LTD.</b> BANGALORE-560073 (INDIA)	NAME		DATE
		DRAWN	J.P.KAUSHIK	09-11-2009
1. ALL DIMENSIONS ARE IN mm. 2. ROUND OFF ALL SHARP CORNERS WITH 0.40 mm. 3. TOLERANCES WILL BE AS PER BS:EN-755 UNLESS OTHERWISE SPECIFIED		CHECKED		
		APPROVED	S.S.GARG	04-07-2010
PARTY'S NAME		SCALE		1:1
		AREA mm <sup>2</sup>		190.238
PARTY'S DRAWING No.		PERIMETER mm.		227.293
		WEIGHT kg/m		0.514
ALLOY & TEMPER		DRAWING No.	SECTION No.	
		P-8969-1	-	
DESCRIPTION		21318	21318	
EASA HUSAIN AL-YOUSIFI & SONS CO., KUWAIT				
AS PER SKETCH				
6063 T6				
LOUVER SECTION				