

P-10281

21323

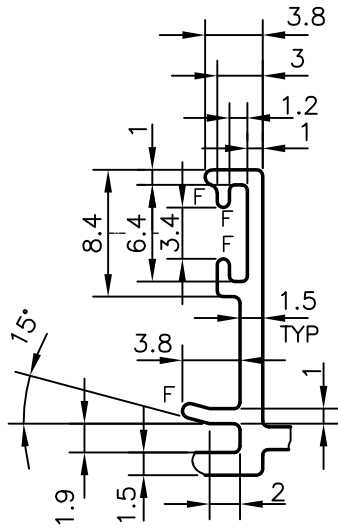

DETAIL OF "A"  
SCALE 2:1

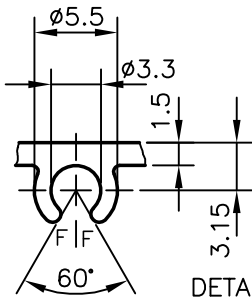
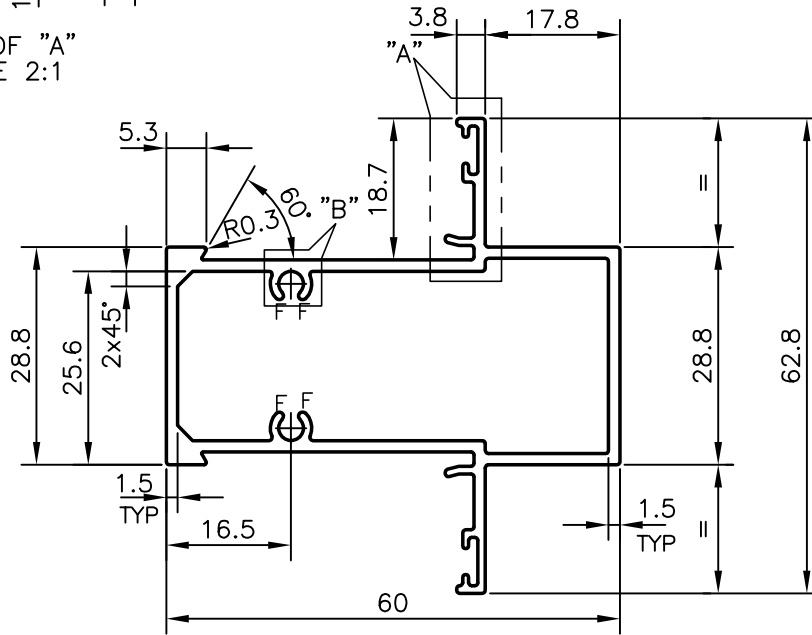
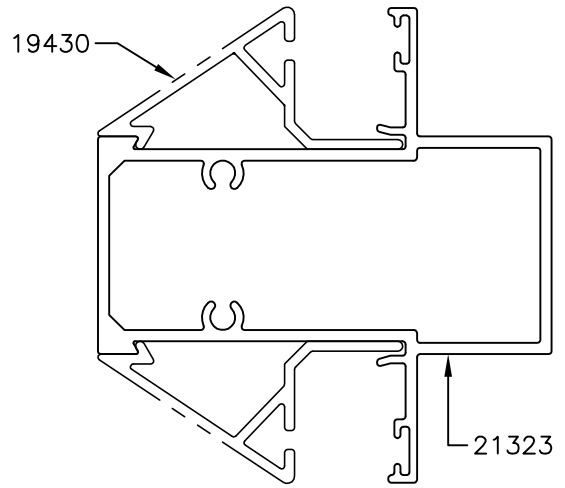

DETAIL OF "B"  
SCALE 2:1

F = FULL RADIUS (12 PLACES)



SYMBOL OF QUALITY  
AN ISO 9001 COMPANY

**JINDAL ALUMINIUM LTD.**  
BANGALORE-560073 (INDIA)

	NAME	DATE
DRAWN	J.P.KAUSHIK	08-08-2010
CHECKED		
APPROVED	S.S.GARG	09-10-2010

1. ALL DIMENSIONS ARE IN mm.
2. ROUND OFF ALL SHARP CORNERS WITH 0.40 mm.
3. TOLERANCES WILL BE AS PER BS:EN-755 UNLESS OTHERWISE SPECIFIED

SCALE	1:1
AREA mm <sup>2</sup>	361.37
PERIMETER mm.	290.506
WEIGHT kg/m	0.976

PARTY'S NAME PRAYOSHA ENTERPRISES LTD., UGANDA

DRAWING No. SECTION No.

PARTY'S DRAWING No. AS PER SAMPLE

P-10281

-

ALLOY & TEMPER 6063 T6

21323

21323

DESCRIPTION WINDOW SECTION