

P-10282

21324

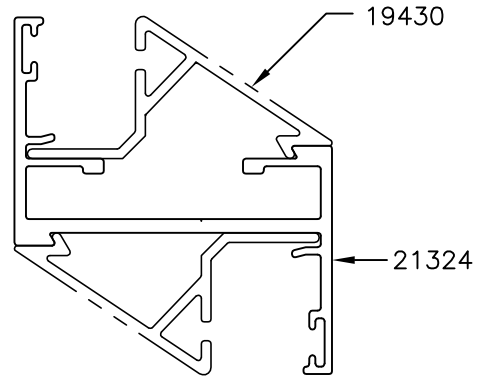

DETAIL OF "A"
SCALE 2:1

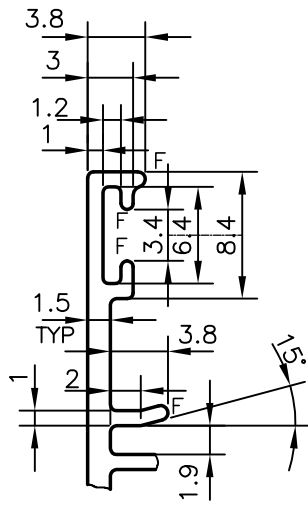
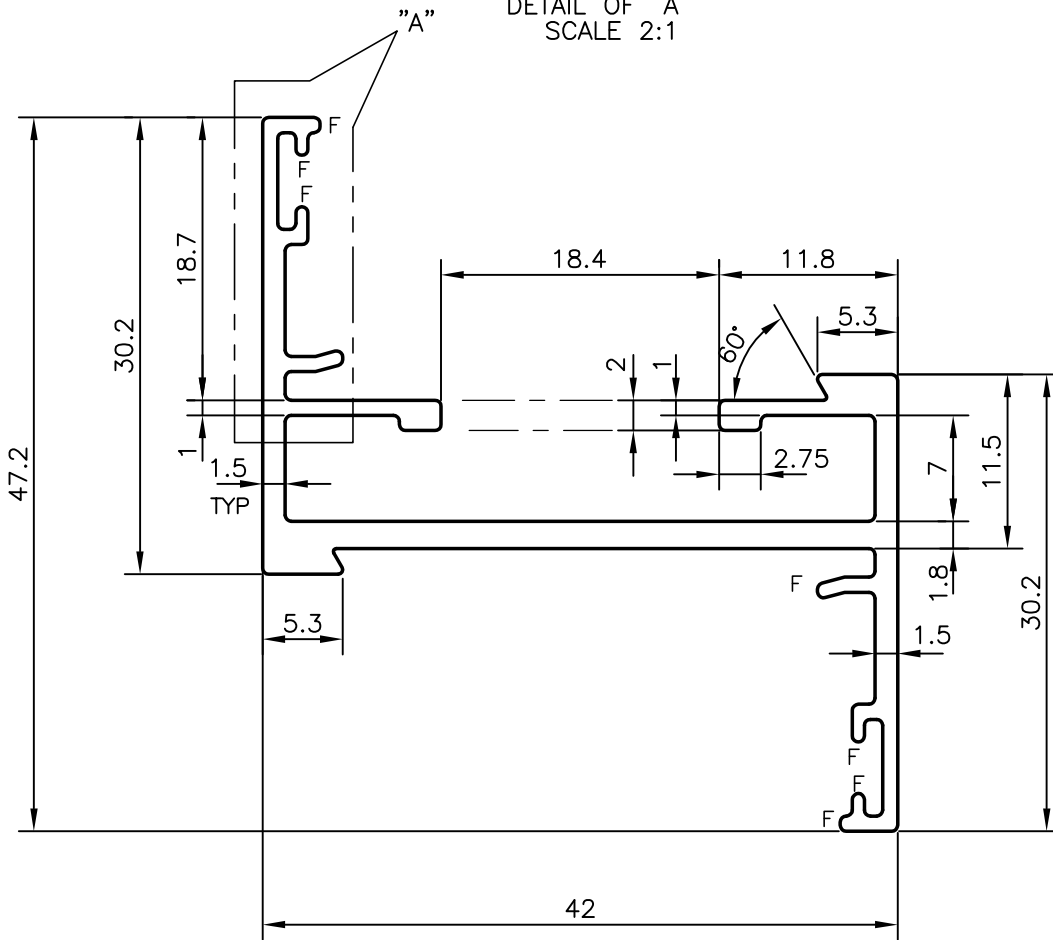

F = FULL RADIUS (8 PLACES)



SYMBOL OF QUALITY
AN ISO 9001 COMPANY

JINDAL ALUMINIUM LTD.
BANGALORE-560073 (INDIA)

| | NAME | DATE |
|----------------------|-------------|------------|
| DRAWN | J.P.KAUSHIK | 08-08-2010 |
| CHECKED | | |
| APPROVED | S.S.GARG | 09-10-2010 |
| SCALE | | 2:1 |
| AREA mm ² | | 212.27 |
| PERIMETER mm. | | 283.133 |
| WEIGHT kg/m | | 0.573 |
| DRAWING No. | SECTION No. | |
| P-10282 | - | |
| 21324 | 21324 | |

1. ALL DIMENSIONS ARE IN mm.
2. ROUND OFF ALL SHARP CORNERS WITH 0.40 mm.
3. TOLERANCES WILL BE AS PER BS:EN-755 UNLESS OTHERWISE SPECIFIED

| | |
|---------------------|-----------------------------------|
| PARTY'S NAME | PRAYOSHA ENTERPRISES LTD., UGANDA |
| PARTY'S DRAWING No. | AS PER SAMPLE |
| ALLOY & TEMPER | 6063 T6 |
| DESCRIPTION | WINDOW SECTION |