

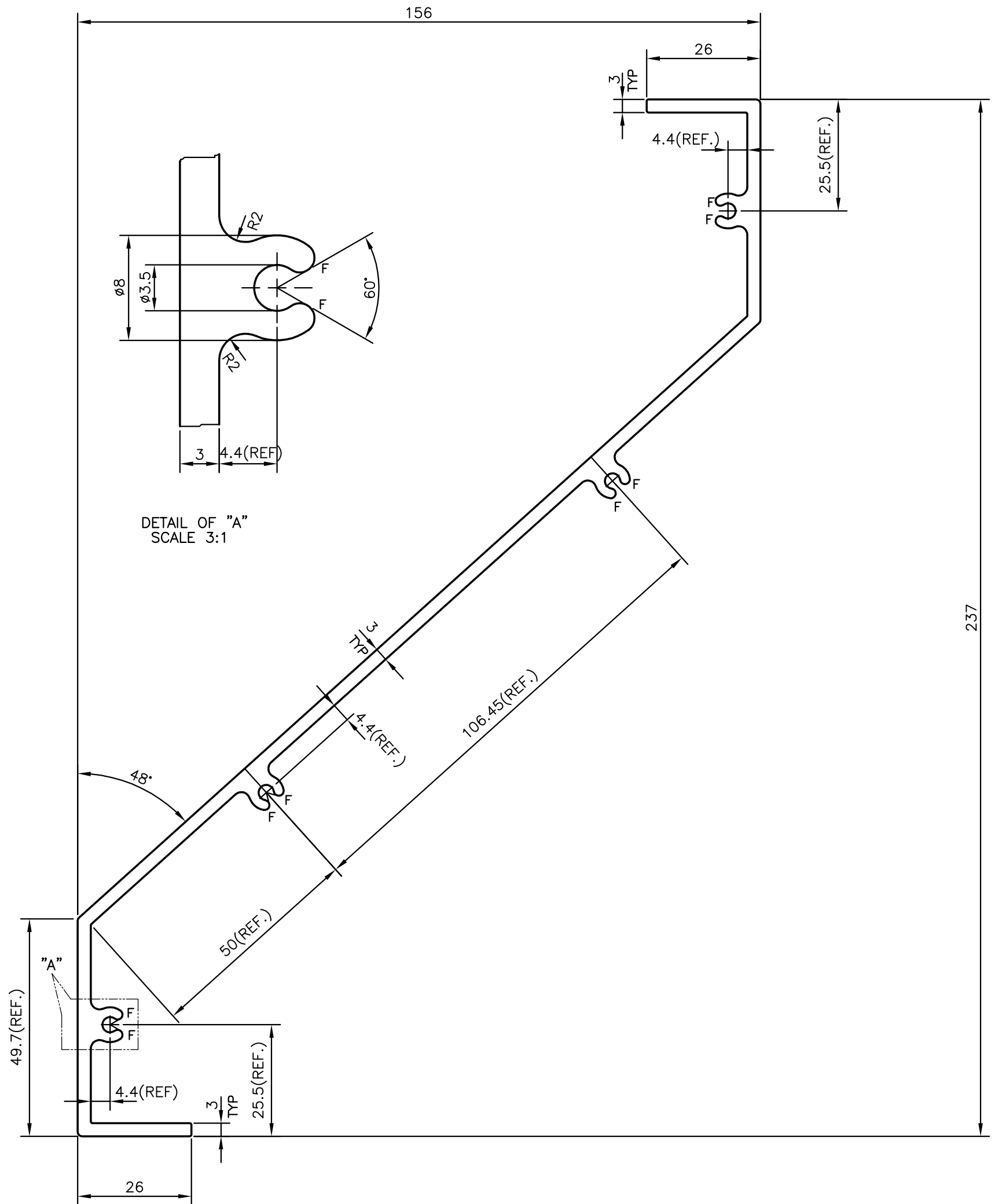

P-10843-1
S2883
21335



F = FULL RADIUS ( 8 PLACES)

 SYMBOL OF QUALITY AN ISO 9001 COMPANY	<b>JINDAL ALUMINIUM LTD.</b> BANGALORE-560073 (INDIA)	DRAWN	J.P.KAUSHIK	18-03-2011
		CHECKED		
1. ALL DIMENSIONS ARE IN mm. 2. ROUND OFF ALL SHARP CORNERS WITH 0.40 mm. 3. TOLERANCES WILL BE AS PER IS:3965-1981 UNLESS OTHERWISE SPECIFIED		APPROVED	S.S.GARG	29-03-2011
		SCALE		1:1
PARTY'S NAME GLASS WALL SYSTEMS(I) PVT. LTD., MUMBAI		AREA	mm <sup>2</sup>	1218.259
		PERIMETER	mm.	787.06
PARTY'S DRAWING No. GWS CAPT.-A3 01		WEIGHT	kg/m	3.289
		DRAWING No.		SECTION No.
ALLOY & TEMPER HE9 WP		P-10843-1		-
		S2883		S2883
DESCRIPTION LOUVER SECTION		21335		21335