

P-11049

21337

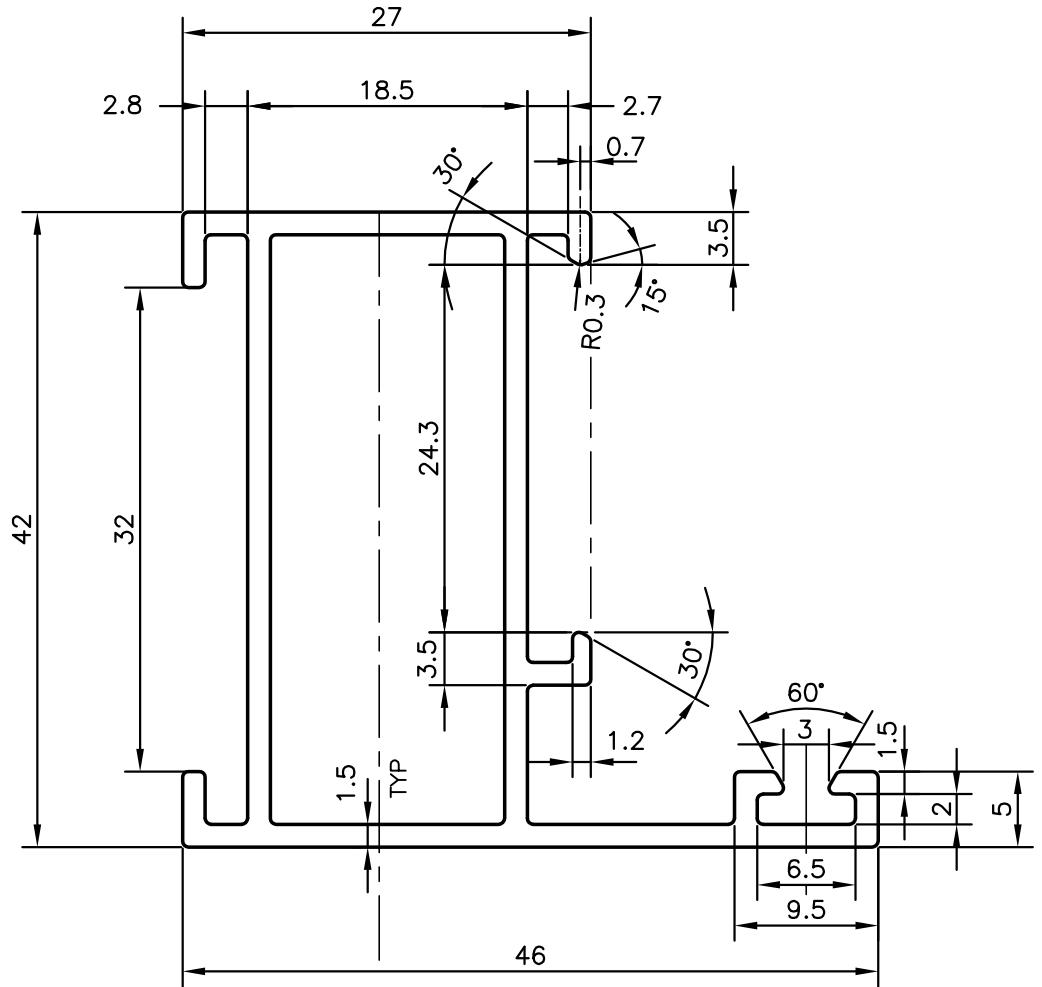
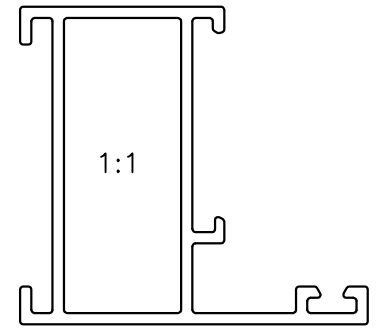

SYMBOL OF QUALITY  
AN ISO 9001 COMPANY

**JINDAL ALUMINIUM LTD.**  
BANGALORE-560073 (INDIA)

	NAME	DATE
DRAWN	J.P.KAUSHIK	25-06-2011
CHECKED		
APPROVED	S.S.GARG	06-07-2011
SCALE		2:1
AREA mm <sup>2</sup>		263.577
PERIMETER mm.		237.477
WEIGHT kg/m		0.712

1. ALL DIMENSIONS ARE IN mm.
2. ROUND OFF ALL SHARP CORNERS WITH 0.40 mm.
3. TOLERANCES WILL BE AS PER, IS:6477-1983 UNLESS OTHERWISE SPECIFIED

PARTY'S NAME	GENERAL CATEGORY, CHENNAI MARKET	DRAWING No.	P-11049	SECTION No.	-
PARTY'S DRAWING No.	AS PER DRAWING		21337		21337
ALLOY & TEMPER	HE9 WP				
DESCRIPTION	WINDOW SECTION (OUTER FRAME)				