

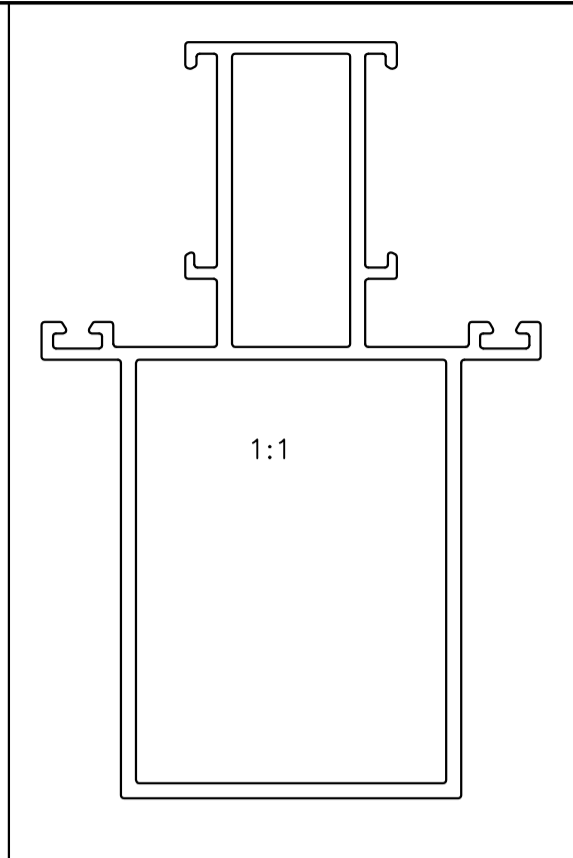

P-11050

21338

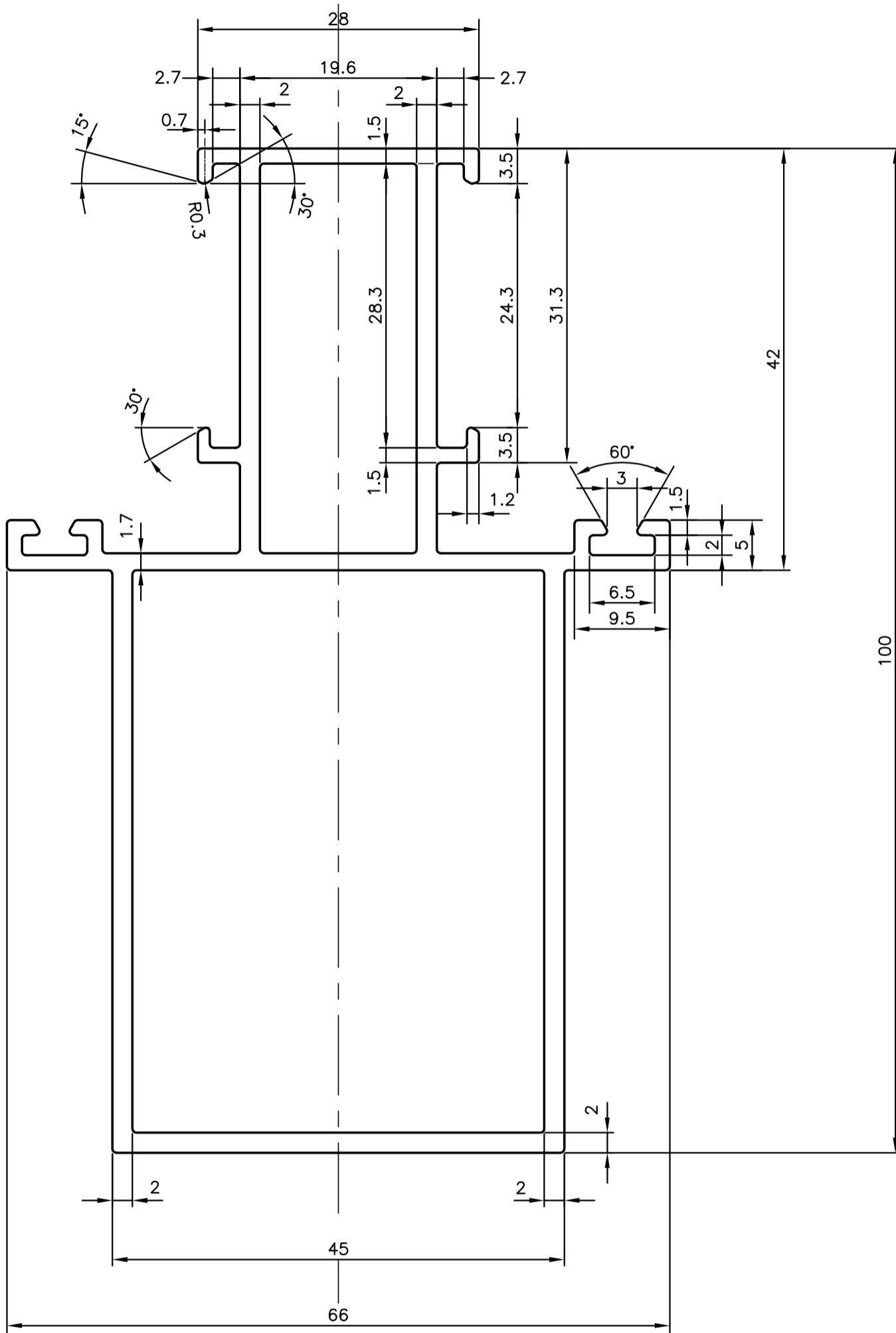

 SYMBOL OF QUALITY AN ISO 9001 COMPANY	<b>JINDAL ALUMINIUM LTD.</b> BANGALORE-560073 (INDIA)		NAME	DATE
			DRAWN	J.P.KAUSHIK
1. ALL DIMENSIONS ARE IN mm. 2. ROUND OFF ALL SHARP CORNERS WITH 0.40 mm. 3. TOLERANCES WILL BE AS PER IS:6477-1983 UNLESS OTHERWISE SPECIFIED			CHECKED	
			APPROVED	S.S.GARG
PARTY'S NAME GENERAL CATEGORY, CHENNAI MARKET			SCALE	2:1
			AREA mm <sup>2</sup>	673.037
PARTY'S DRAWING No. AS PER DRAWING			PERIMETER mm.	411.847
			WEIGHT kg/m	1.817
ALLOY & TEMPER HE9 WP			DRAWING No.	SECTION No.
			P-11050	-
DESCRIPTION WINDOW SECTION (MULLION)			21338	21338