

P-11082

21339

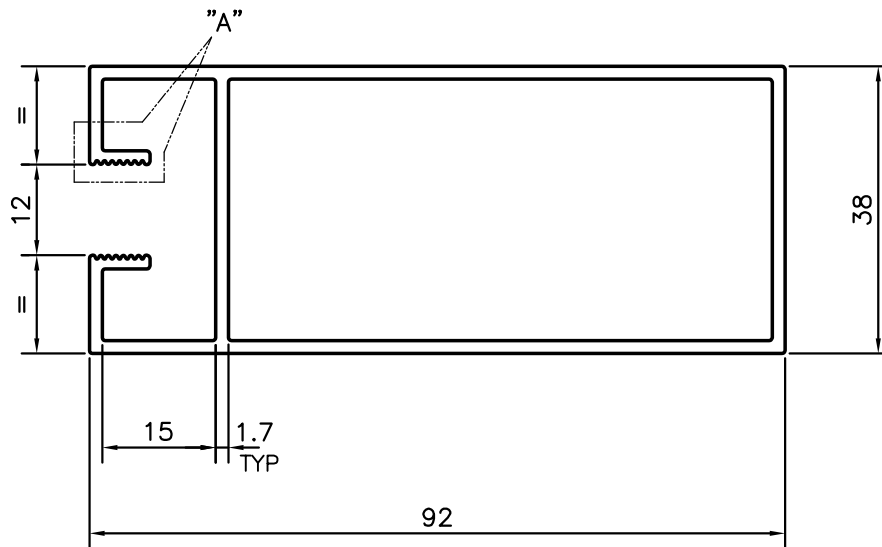
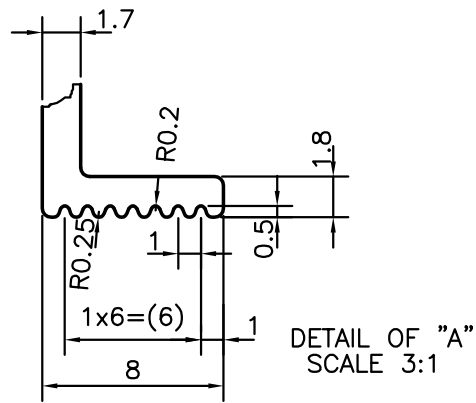

SYMBOL OF QUALITY
AN ISO 9001 COMPANY

JINDAL ALUMINIUM LTD.
BANGALORE-560073 (INDIA)

	NAME	DATE
DRAWN	J.P.KAUSHIK	09-07-2011
CHECKED		
APPROVED	S.S.GARG	25-07-2011
SCALE		1:1
AREA mm ²		488.227
PERIMETER mm.		368.551
WEIGHT kg/m		1.318

1. ALL DIMENSIONS ARE IN mm.
2. ROUND OFF ALL SHARP CORNERS WITH 0.40 mm.
3. TOLERANCES WILL BE AS PER, BS:EN-755 UNLESS OTHERWISE SPECIFIED

PARTY'S NAME	GENERAL CATEGORY (DELHI MARKET)	DRAWING No.	SECTION No.
PARTY'S DRAWING No.	AS PER SKETCH	P-11082	-
ALLOY & TEMPER	HE9 WP	21339	21339
DESCRIPTION	WINDOW SECTION		