

P-9204

X1169

21341

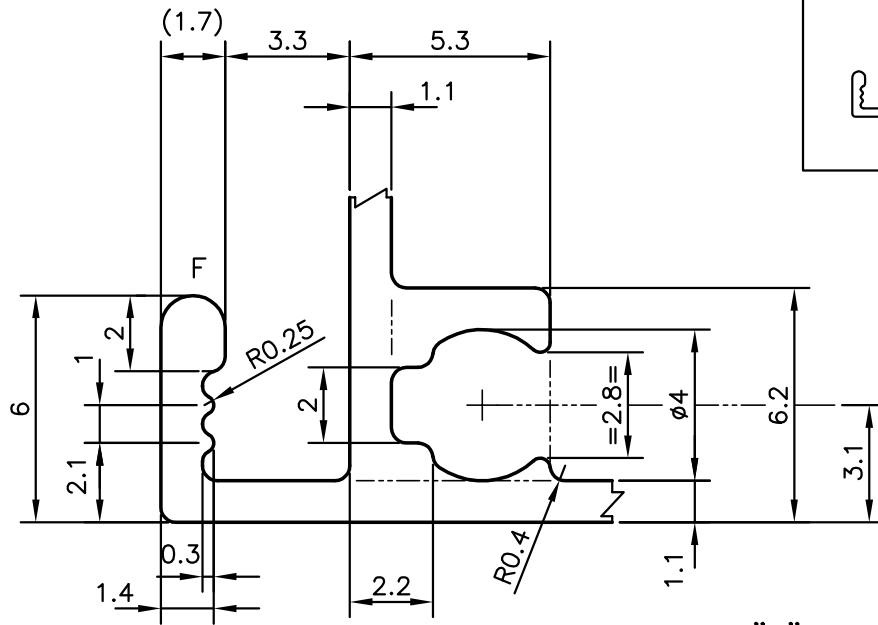
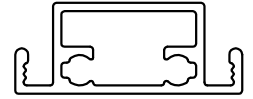

DETAIL OF "A"
SCALE 5:1

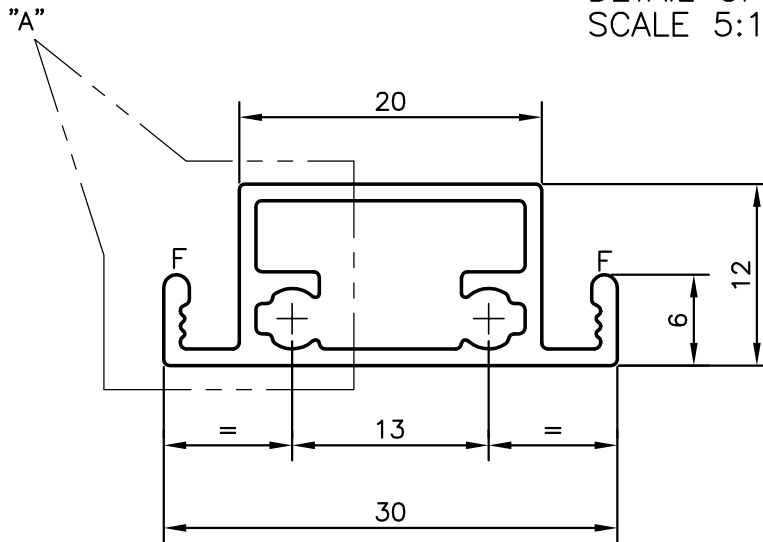

F = FULL RADIUS

GENERAL WALL THICKNESS 1.10 mm



SYMBOL OF QUALITY
AN ISO 9001 COMPANY

JINDAL ALUMINIUM LTD.
BANGALORE-560073 (INDIA)

	NAME	DATE
DRAWN	J.P.KAUSHIK	08-05-2009
CHECKED		
APPROVED		

1. ALL DIMENSIONS ARE IN mm.
2. ROUND OFF ALL SHARP CORNERS WITH 0.40 mm.
3. TOLERANCES WILL BE AS PER IS:6477-1983 UNLESS OTHERWISE SPECIFIED

SCALE	2:1
AREA mm ²	106.167
PERIMETER mm.	103.443
WEIGHT kg/m	0.287

PARTY'S NAME	KARTHIK INDUSTRIES, BANGALORE
PARTY'S DRAWING No.	AS PER SAMPLE
ALLOY & TEMPER	HE9 WP
DESCRIPTION	FLY SCREEN SECTION

DRAWING No.	SECTION No.
P-9204	-
X1169	X1169
21341	21341