

P-11023

S2975

21347

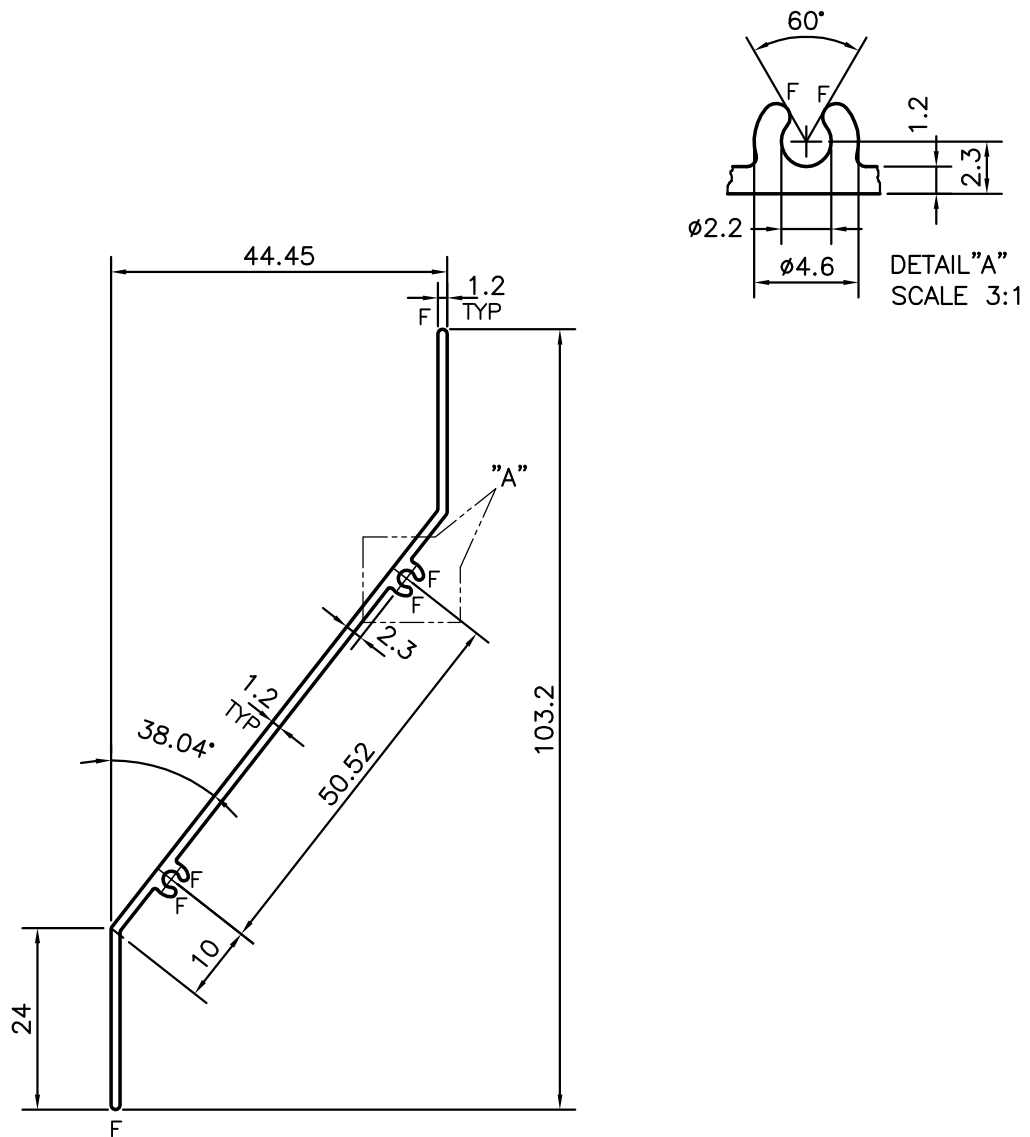

F = FULL RADIUS (6 PLACES)



SYMBOL OF QUALITY
AN ISO 9001 COMPANY

JINDAL ALUMINIUM LTD.
BANGALORE-560073 (INDIA)

	NAME	DATE
DRAWN	J.P.KAUSHIK	11-06-2011
CHECKED		
APPROVED	S.S.GARG	15-06-2011
SCALE		1:1
AREA mm ²		155.495
PERIMETER mm.		256.25
WEIGHT kg/m		0.420
DRAWING No.	SECTION No.	
P-11023	-	
S2975	S2975	
21347	21347	

1. ALL DIMENSIONS ARE IN mm.
2. ROUND OFF ALL SHARP CORNERS WITH 0.40 mm.
3. TOLERANCES WILL BE AS PER, BS:EN-755-9 UNLESS OTHERWISE SPECIFIED

PARTY'S NAME	TRIDENT ARCHITECTURAL ALUMINIUM PRODUCTS PVT. LTD., BANGALORE
PARTY'S DRAWING No.	AS PER DRAWING PROFILE-3
ALLOY & TEMPER	HE9 WP
DESCRIPTION	LOUVER SECTION