

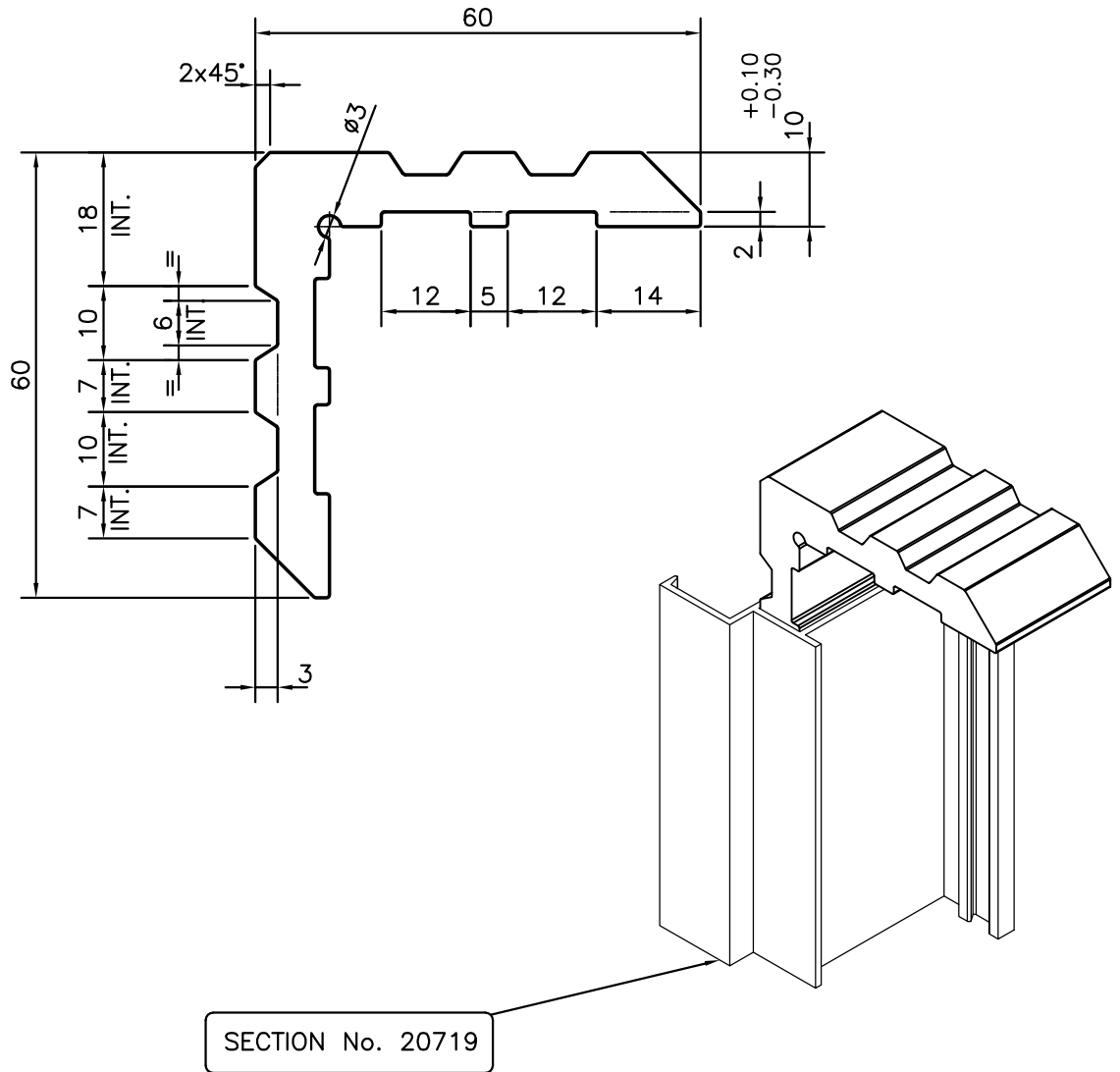

P-11328-1

21362



SECTION No. 20719

 SYMBOL OF QUALITY AN ISO 9001 COMPANY	JINDAL ALUMINIUM LTD. BANGALORE-560073 (INDIA)	NAME		DATE
		DRAWN	J.P.KAUSHIK	30-11-2011
1. ALL DIMENSIONS ARE IN mm. 2. ROUND OFF ALL SHARP CORNERS WITH 0.40 mm. 3. TOLERANCES WILL BE AS PER, IS:3965-1981 UNLESS OTHERWISE SPECIFIED		CHECKED		
		APPROVED	S.S.GARG	03-12-2011
PARTY'S NAME		SCALE		1:1
		AREA mm ²		836.561
PARTY'S DRAWING No.		PERIMETER mm.		258.351
		WEIGHT kg/m		2.259
ALLOY & TEMPER		DRAWING No.		SECTION No.
		P-11328-1		
DESCRIPTION		21362		21362
MISC. ANGLE				