

P-9489-1

S2288

21364

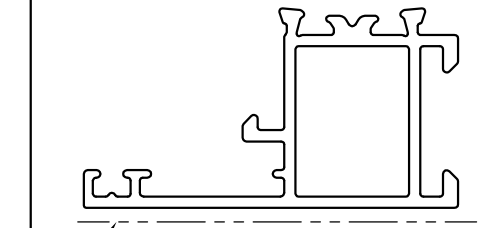
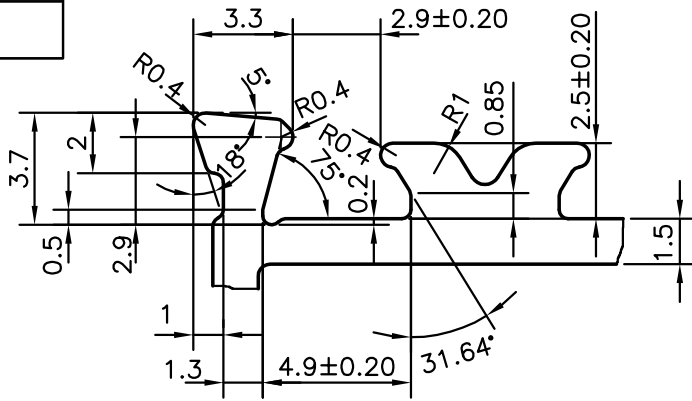

EXPOSED SURFACE

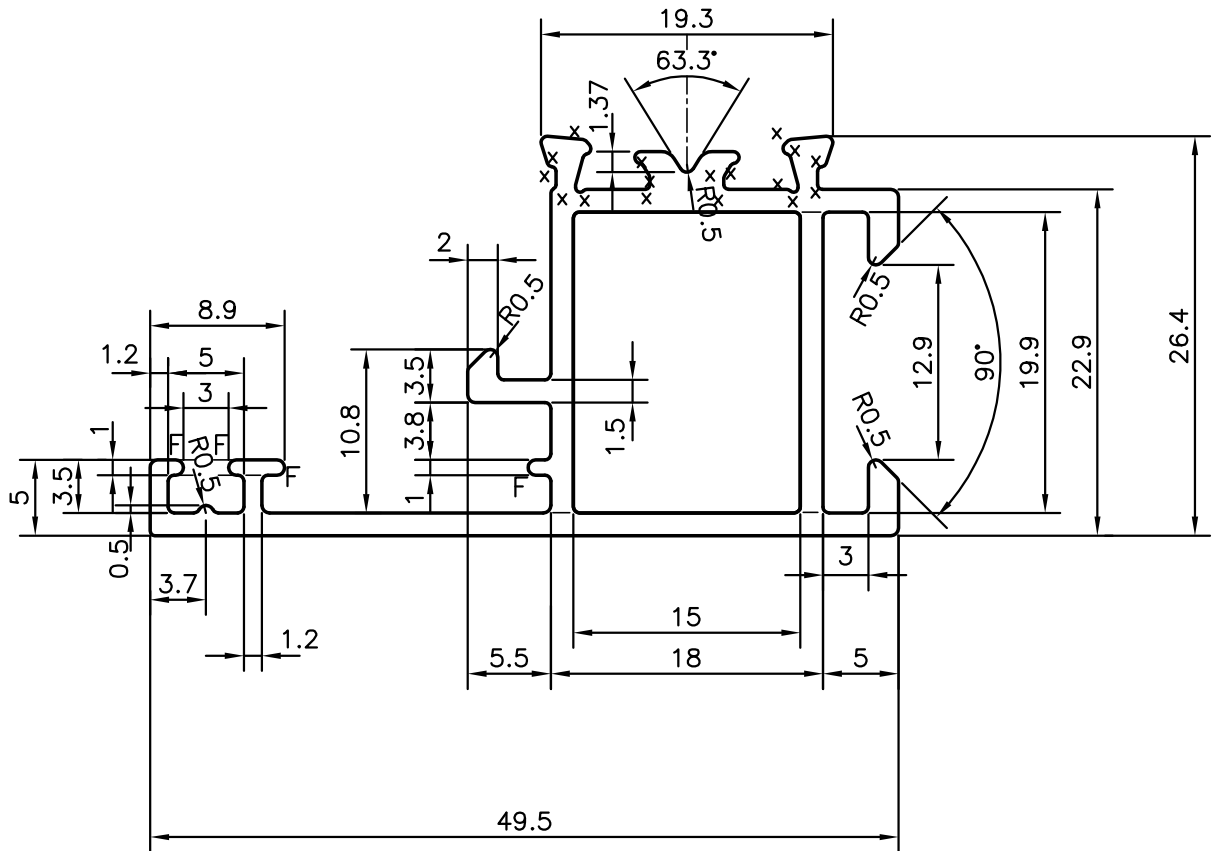

x = 0.3 RADIUS (16 PLACES)
 F = FULL RADIUS (4 PLACES)



SYMBOL OF QUALITY
 AN ISO 9001 COMPANY

JINDAL ALUMINIUM LTD.
 BANGALORE-560073 (INDIA)

	NAME	DATE
DRAWN	J.P.KAUSHIK	29-09-2009
CHECKED		
APPROVED		

1. ALL DIMENSIONS ARE IN mm.
2. ROUND OFF ALL SHARP CORNERS WITH 0.40 mm.
3. TOLERANCES WILL BE AS PER IS:6477-1983 UNLESS OTHERWISE SPECIFIED

SCALE	2:1
AREA mm ²	232.762
PERIMETER mm.	226.118
WEIGHT kg/m	0.628

PARTY'S NAME AGV FENESTRATION PVT.LTD.,SIRMOUR

DRAWING No. SECTION No.

PARTY'S DRAWING No. AS PER DRAWING

P-9489-1

ALLOY & TEMPER HE9 WP

S2288

S2288

DESCRIPTION

WINDOW SECTION

21364

21364