

P-9492-1

S2291

21367

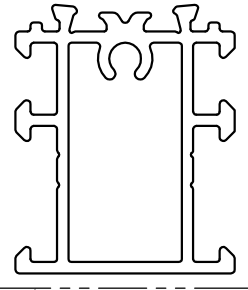
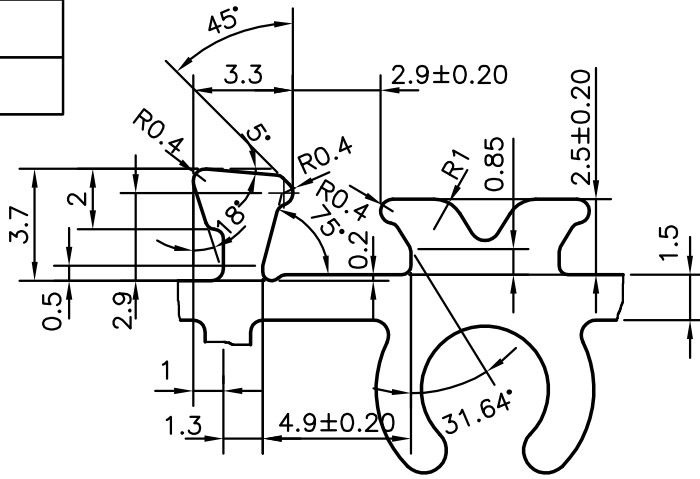

EXPOSED SURFACE

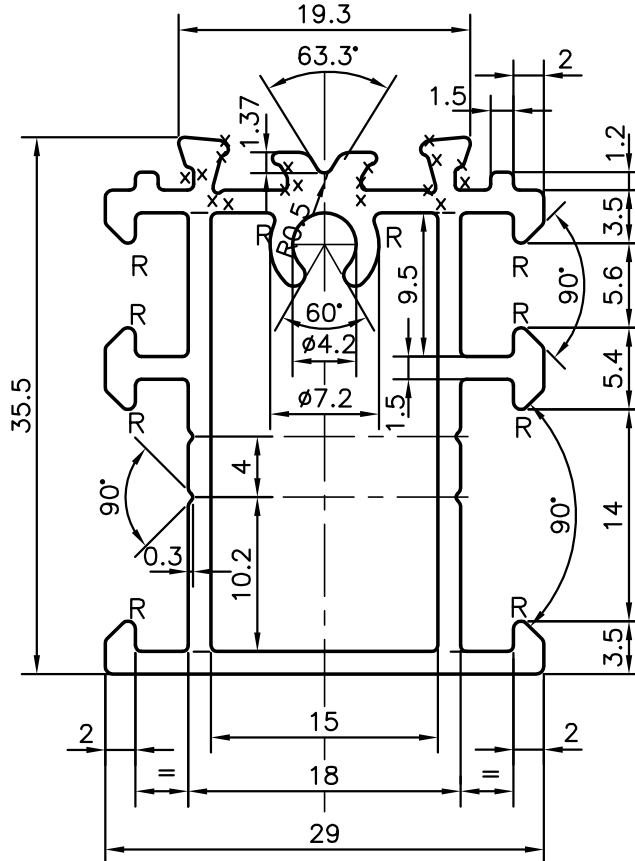

R = 0.5 RADIUS (10 PLACES)
 x = 0.3 RADIUS (16 PLACES)



SYMBOL OF QUALITY
 AN ISO 9001 COMPANY

JINDAL ALUMINIUM LTD.
 BANGALORE-560073 (INDIA)

	NAME	DATE
DRAWN	J.P.KAUSHIK	29-09-2009
CHECKED		
APPROVED		

1. ALL DIMENSIONS ARE IN mm.
2. ROUND OFF ALL SHARP CORNERS WITH 0.40 mm.
3. TOLERANCES WILL BE AS PER IS:6477-1983 UNLESS OTHERWISE SPECIFIED

SCALE	2:1
AREA mm ²	261.247
PERIMETER mm.	216.629
WEIGHT kg/m	0.705

PARTY'S NAME	AGV FENESTRATION PVT LTD., SIRMOUR
PARTY'S DRAWING No.	AS PER DRAWING
ALLOY & TEMPER	HE9WP
DESCRIPTION	WINDOW SECTION

DRAWING No.	SECTION No.
P-9492-1	
S2291	S2291
21367	21367