

P-9878

X1266

21388

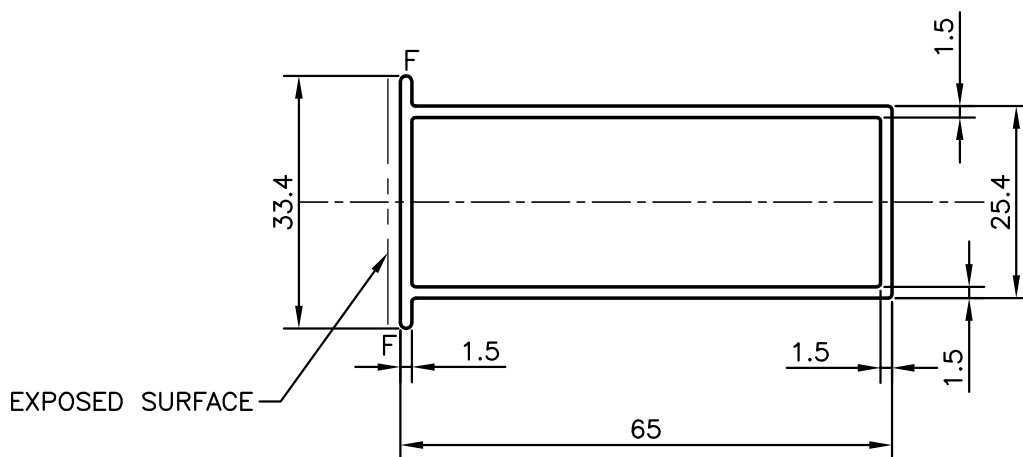

F = FULL RADIUS (2 PLACES)
UNSPECIFIED RADII 0.5 mm



SYMBOL OF QUALITY
AN ISO 9001 COMPANY

JINDAL ALUMINIUM LTD.
BANGALORE-560073 (INDIA)

	NAME	DATE
DRAWN	J.P.KAUSHIK	09-03-2010
CHECKED		
APPROVED	S.S.GARG	23-03-2010
SCALE		1:1
AREA mm ²		273.932
PERIMETER mm.		194.654
WEIGHT kg/m		0.740
DRAWING No.	SECTION No.	
P-9878	-	
X1266	X1266	
21388	21388	

1. ALL DIMENSIONS ARE IN mm.
2. ROUND OFF ALL SHARP CORNERS WITH 0.50 mm.
3. TOLERANCES WILL BE AS PER IS:6477-1983, UNLESS OTHERWISE SPECIFIED

PARTY'S NAME	GEETA ALUMINIUM CO. PVT. LTD., MUMBAI
PARTY'S DRAWING No.	AS PER DRAWING
ALLOY & TEMPER	HE9 WP
DESCRIPTION	ARCHITECTURAL SECTION